

1

AT SCHOOL

What is wrong? Find and circle.

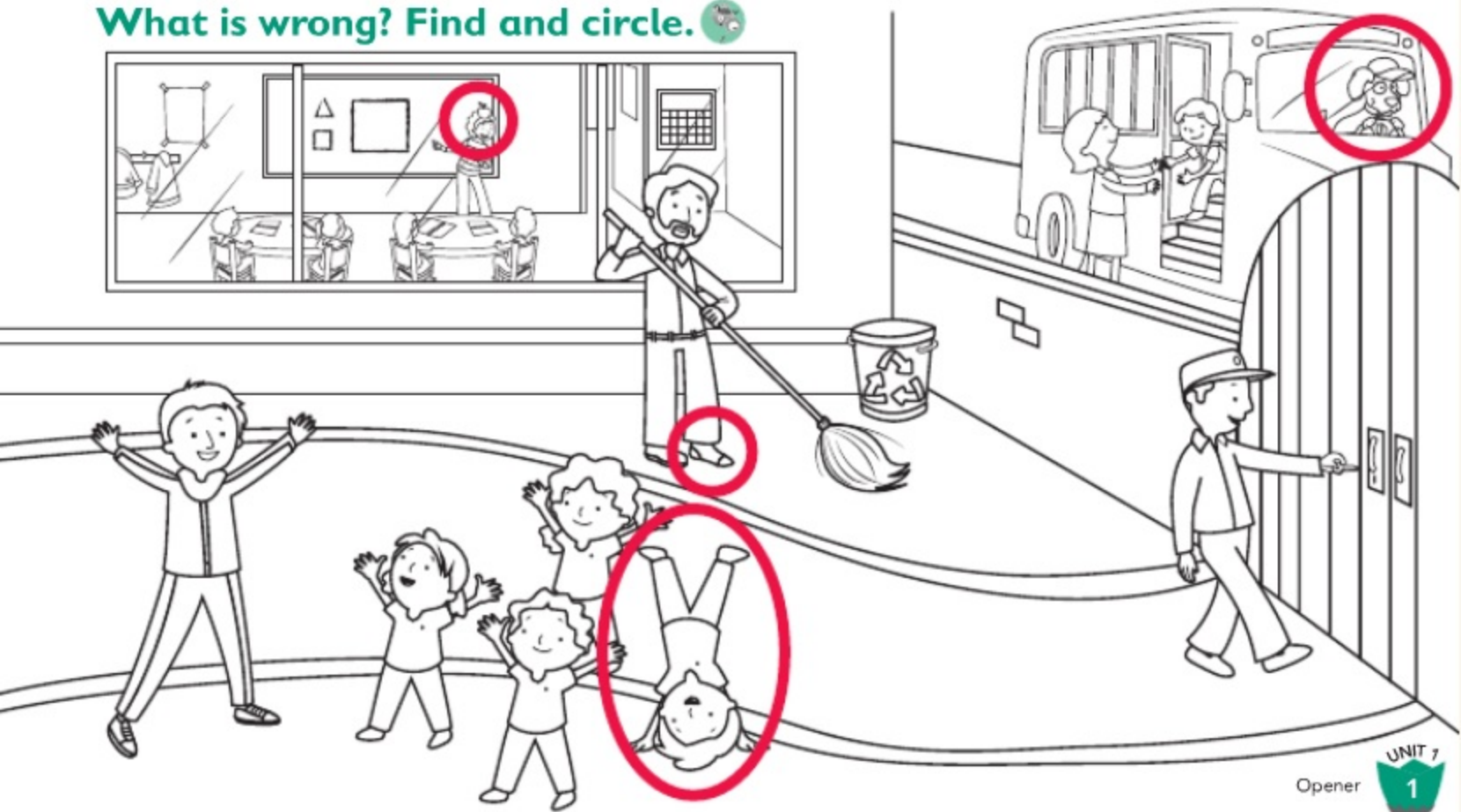

Draw the English teacher and the principal.

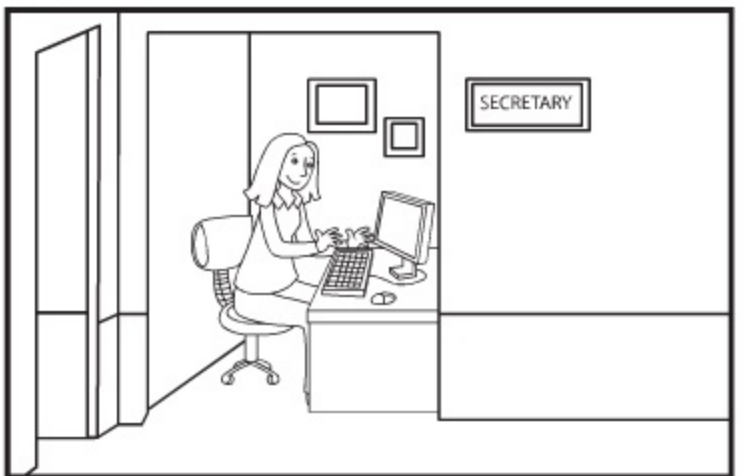
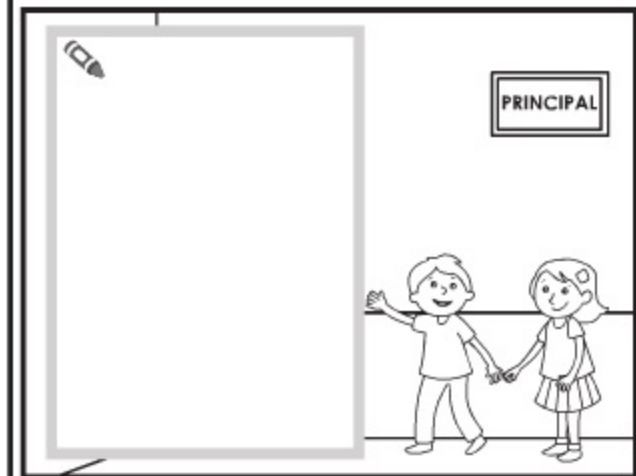
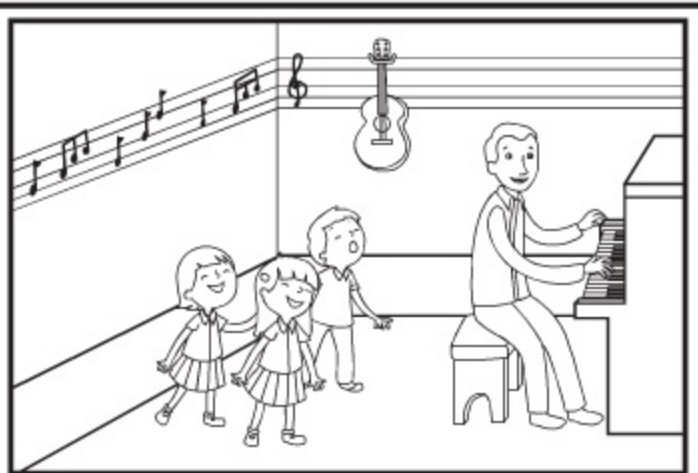
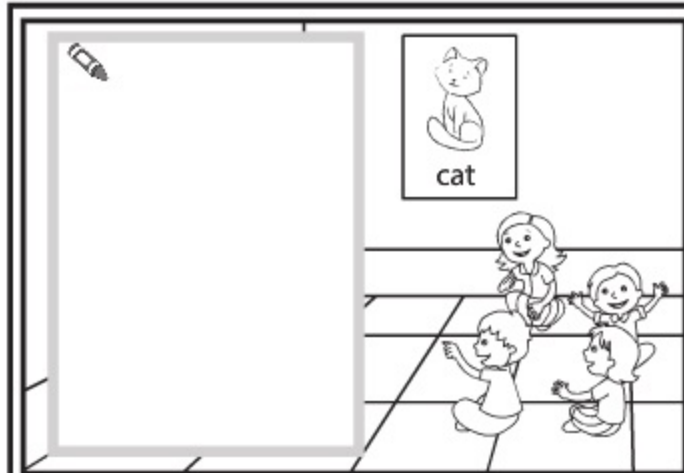

Look and match.



Vocabulary Practice: gym teacher, janitor, gatekeeper



✂ Cut out and paste. Draw yourself and color.

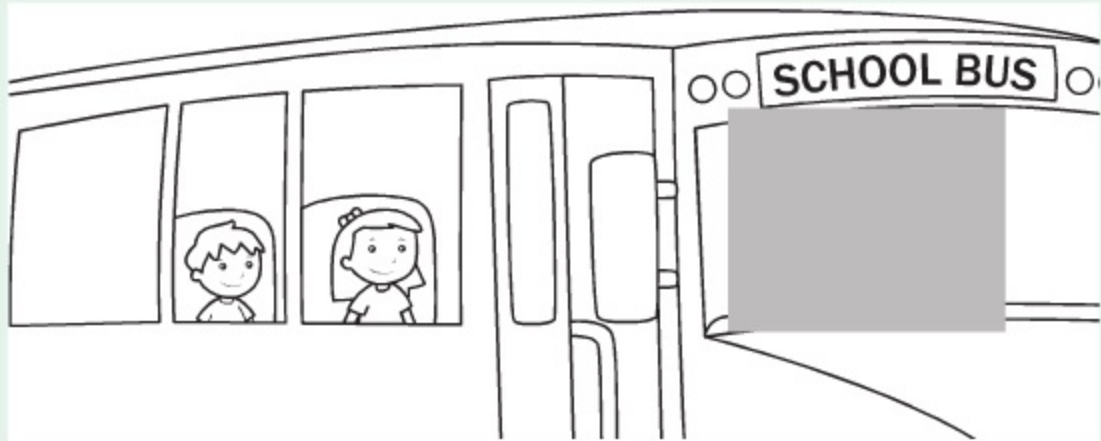

Look and circle the correct letter. Trace and draw.



a **f**



a m

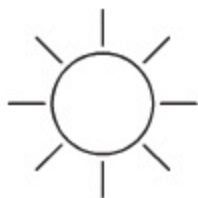

s m



f **m**

F f

A a

S s

M m

VALUES

Look, trace, and draw a happy face or a sad face.

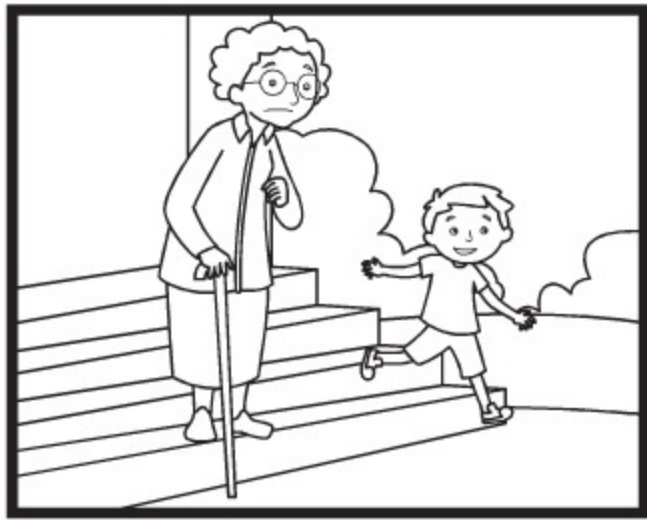



Listen and point. Listen again, match, and trace the numbers.

Who Is She?



1

2

3

4

Count, draw and trace. Color.

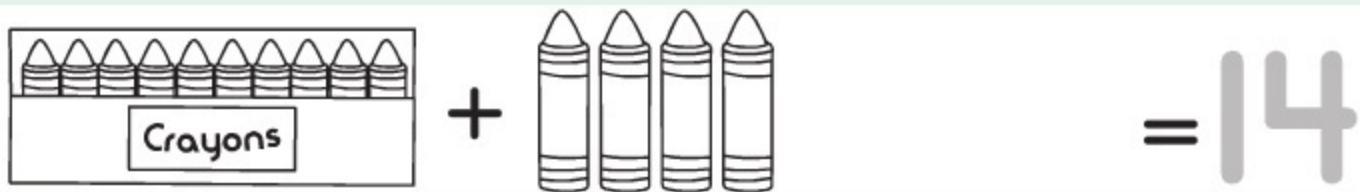

What does each animal make? Look and match. Color.

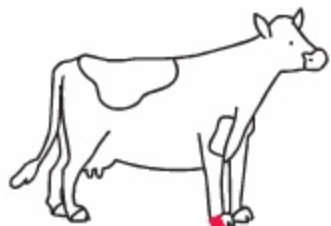

Amazing: Science Connection: cow, milk, bee, honey, chicken, eggs, sheep, wool



AT SCHOOL



Draw people at school.



2

FEELINGS

What is wrong? Find and circle.



Look and color the matching face.



Look and match.



Trace and draw actions that make Mom mad and happy.

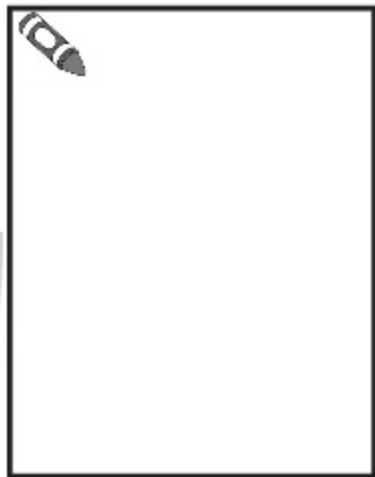
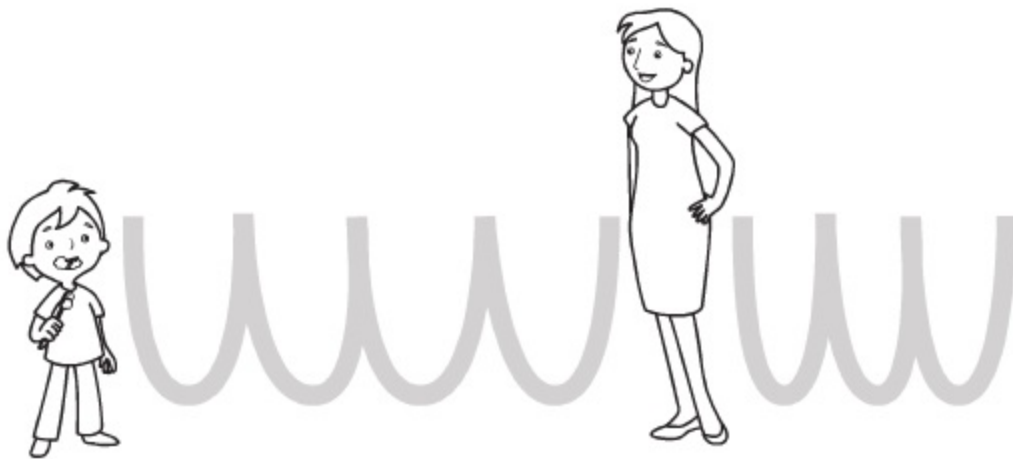
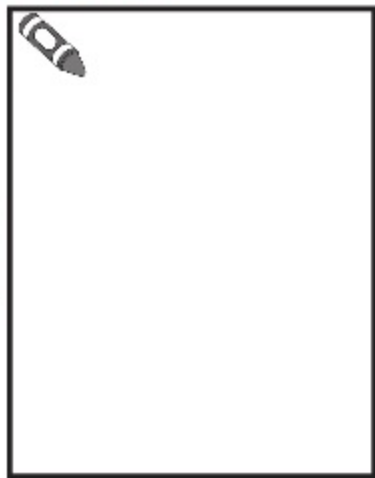

Look and circle the correct letter. Trace and draw.

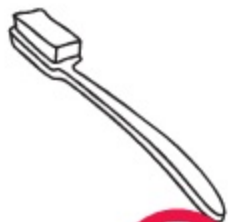

l t



p l



e t



e p



VALUES

Who is staying healthy? Color the frame. Draw.



How do you stay healthy?





Cut out, listen, and paste.

Are You Okay?

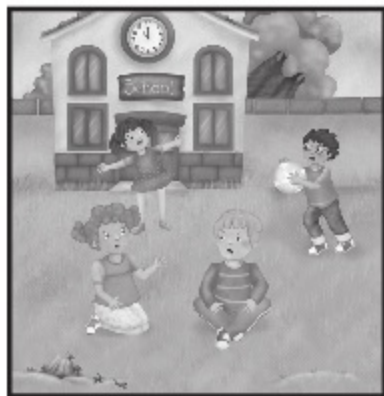

1



2

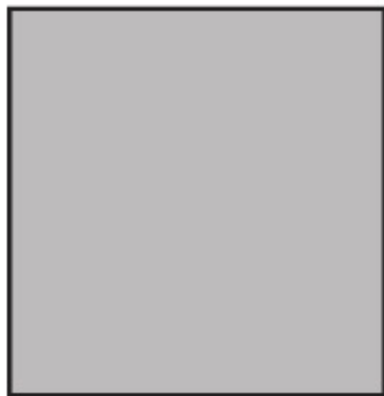

3



4



Count the stars and circle the number. Color.



20

21

22

23

24

25

26

27

28

29

Look and circle the parts of the animals' bodies that protect them.

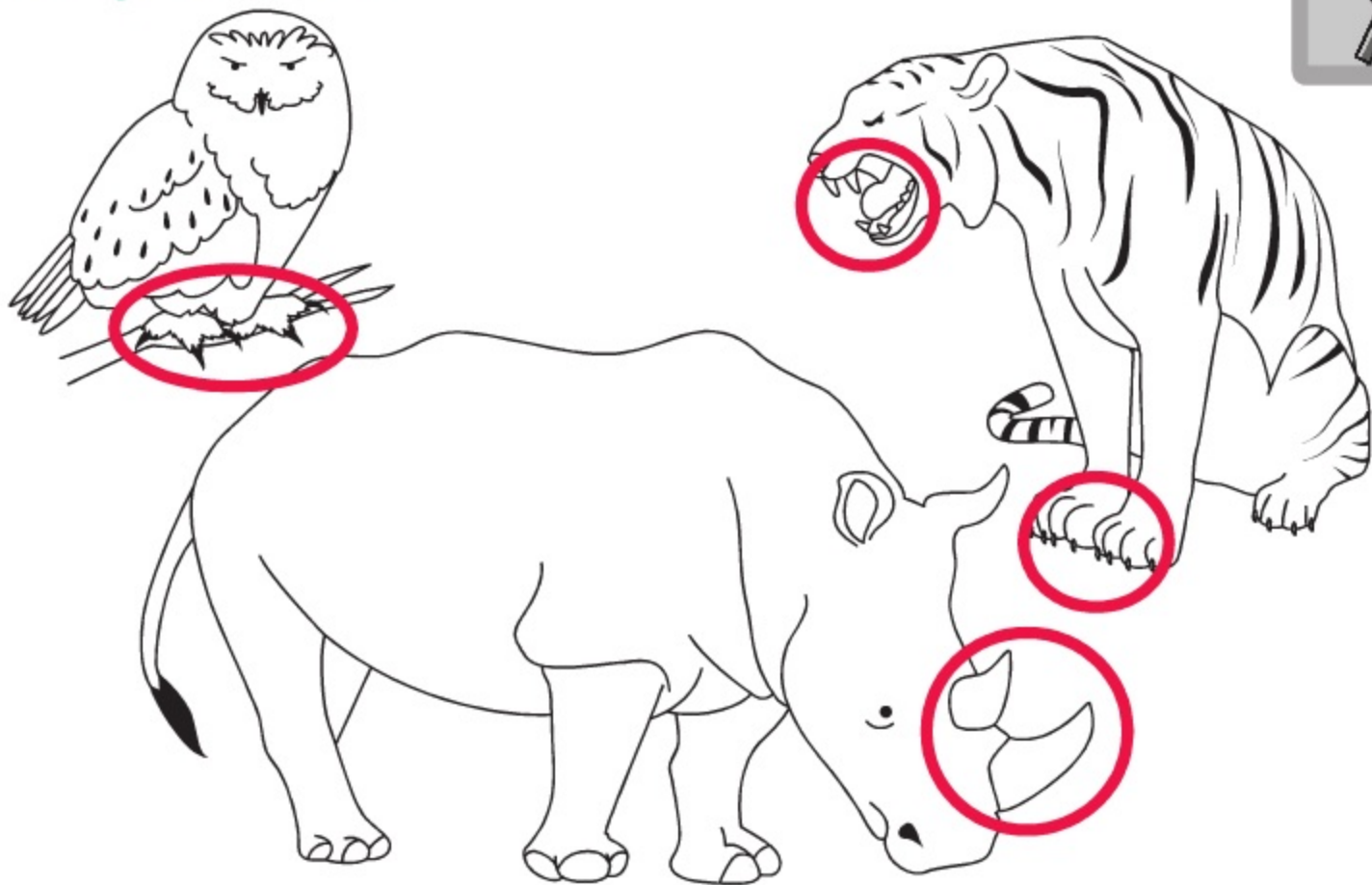

FEELINGS

Draw your feelings.



3

HOME

What is wrong? Find and circle.

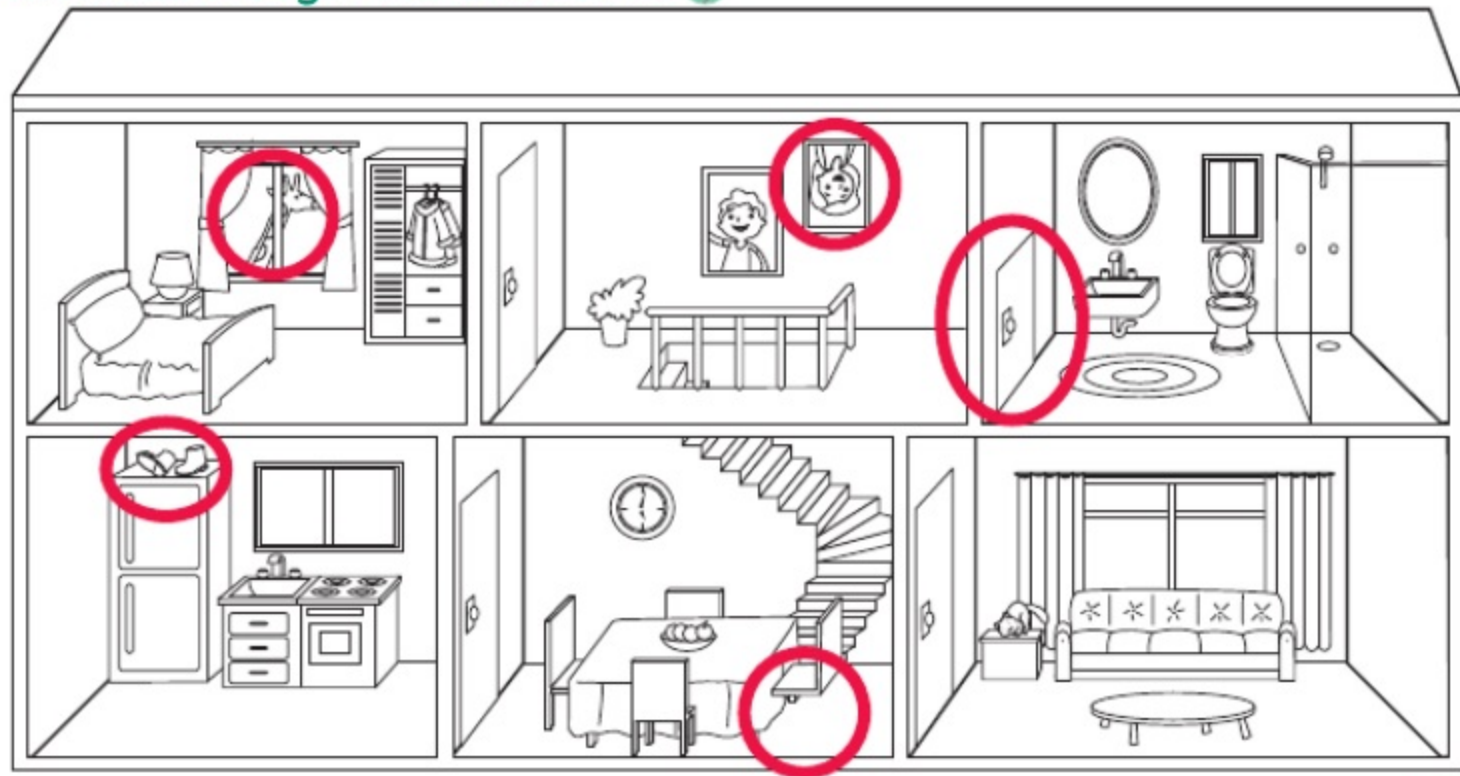

Where are the family members? Look and match.



✂ Cut out and paste. Say.



Vocabulary Practice: dining room, hallway, closet, stairs
Language Practice: Where is (the cat)? It's (in the closet).

What is missing in each room? Trace, draw, and color.

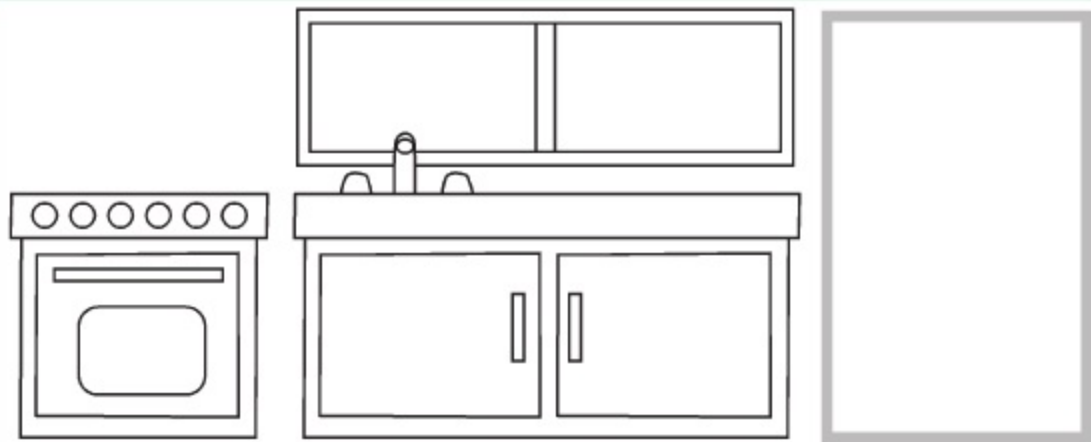

Trace and match.

C

N

I

G

n

g

c

i



VALUES

Are they respecting differences? Complete the face.
Trace and read the sentences.



It is a  .

It is a  .



Look and listen. Draw someone hiding in the box and say.

Where Is Meg?

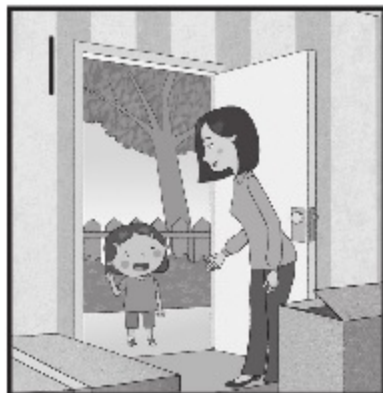

Where is ... ?

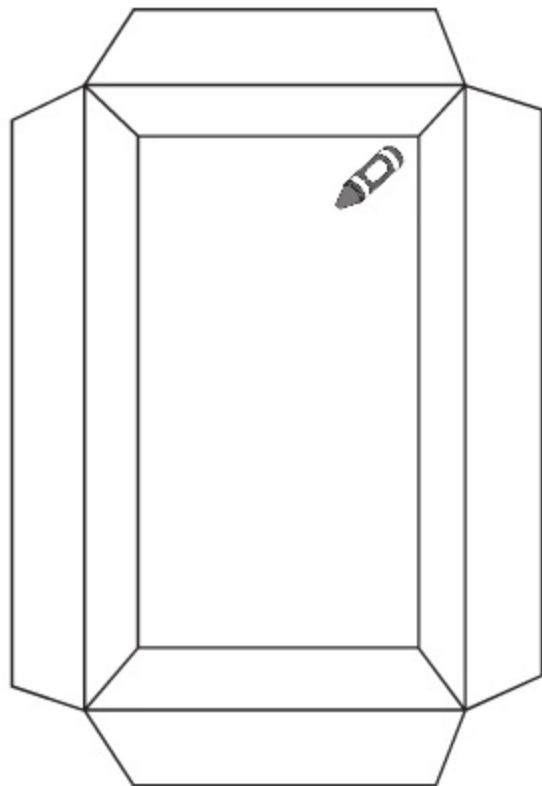

Circle the sets of ten fingers. Count and write.



$$= \underline{34}$$



$$= \underline{38}$$



What is for dinner? Circle an insect and draw it in the spider's web.

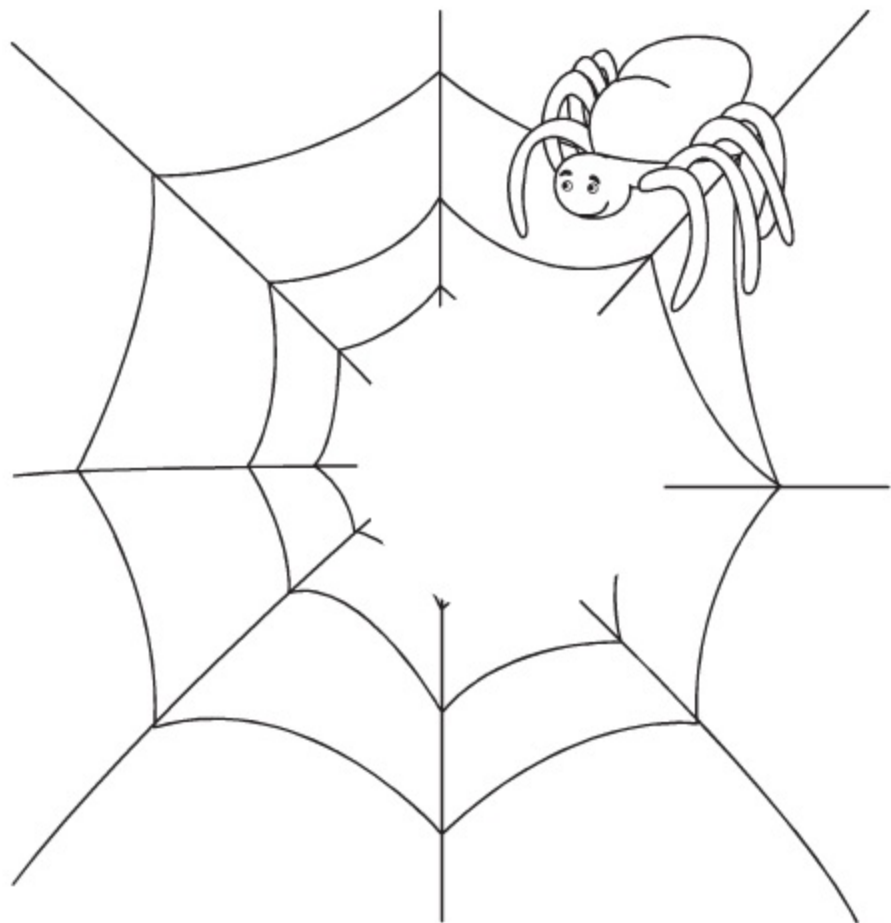
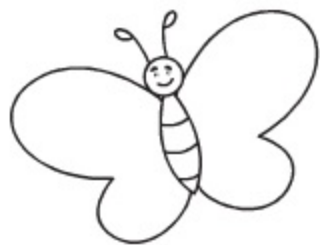



HOME



Draw your favorite place at home.



4

RECYCLE

What is wrong? Find and circle.



What do you need to make a wagon? Look and circle or cross out.

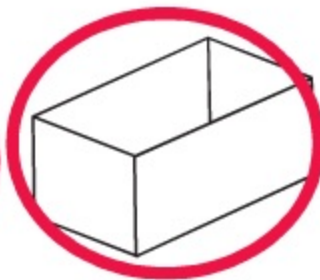
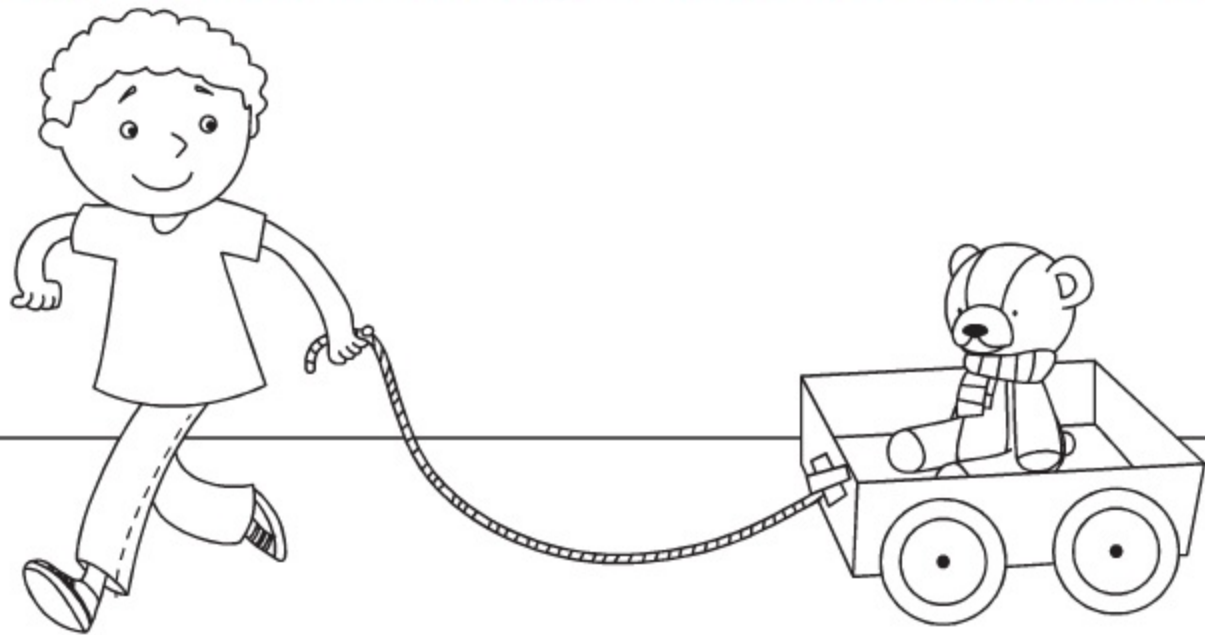

✂ **What do you need to make a kite?**
Cut out and paste.

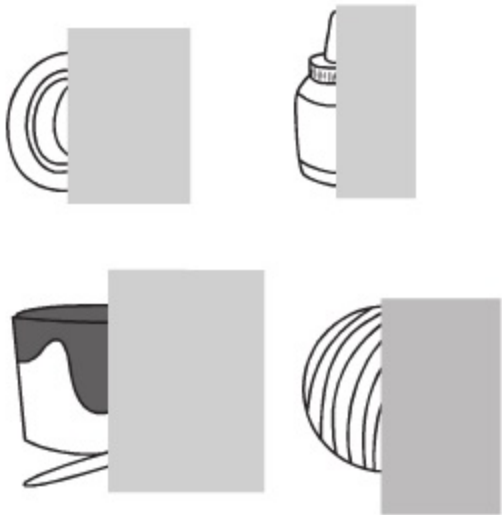
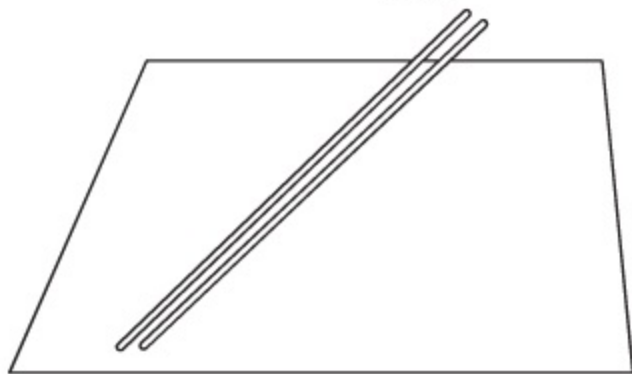

Look and color the crayons and the lion mask.

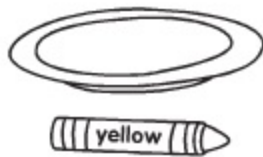
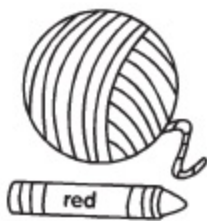

Trace and write. Trace, read, and circle. Trace, read, and draw.

H

R

B

O

h

r

b

o

It is a box.

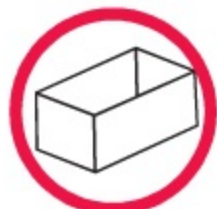

It is a ring.



It is a hat.



VALUES

Is he being wasteful? Draw a happy or a sad face.
Then draw yourself and complete the face.

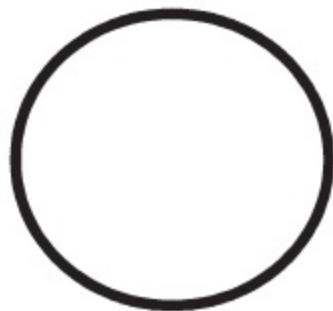
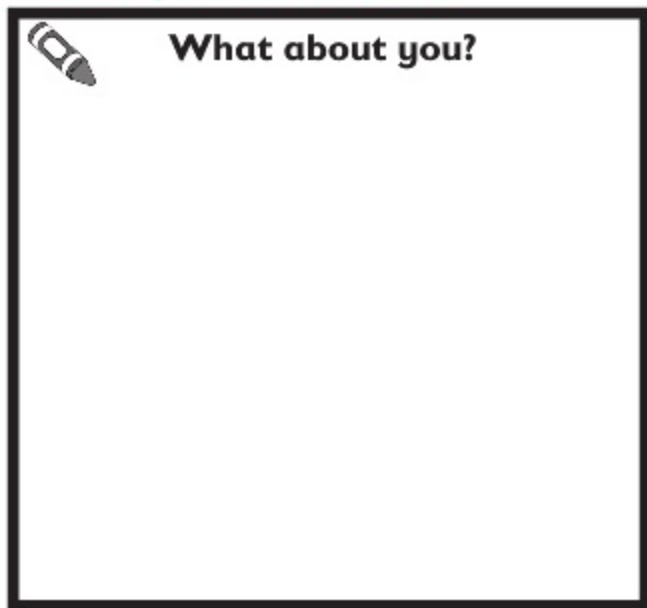
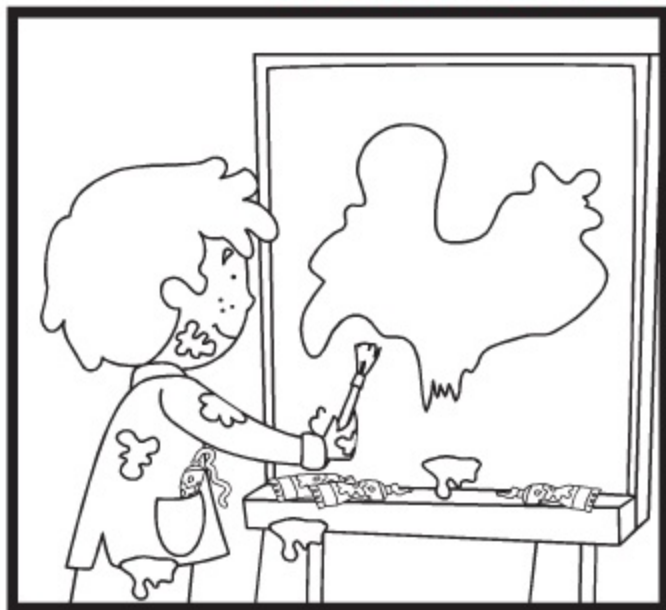



Look and listen. Color what they need to make a tent.

We Need Books!

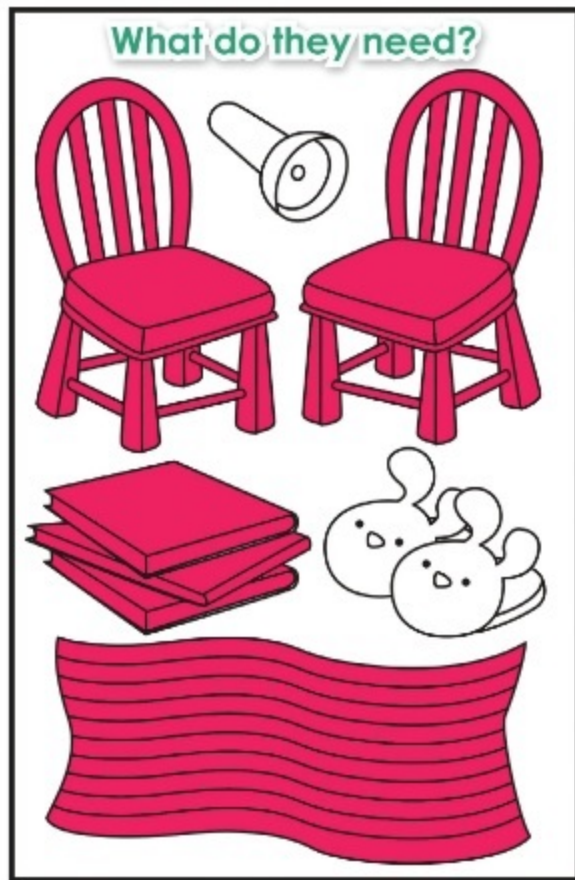

Circle the sets of ten. Draw more flowers to match the numbers.



Trace around the flying seeds. Match and color.

AMAZING

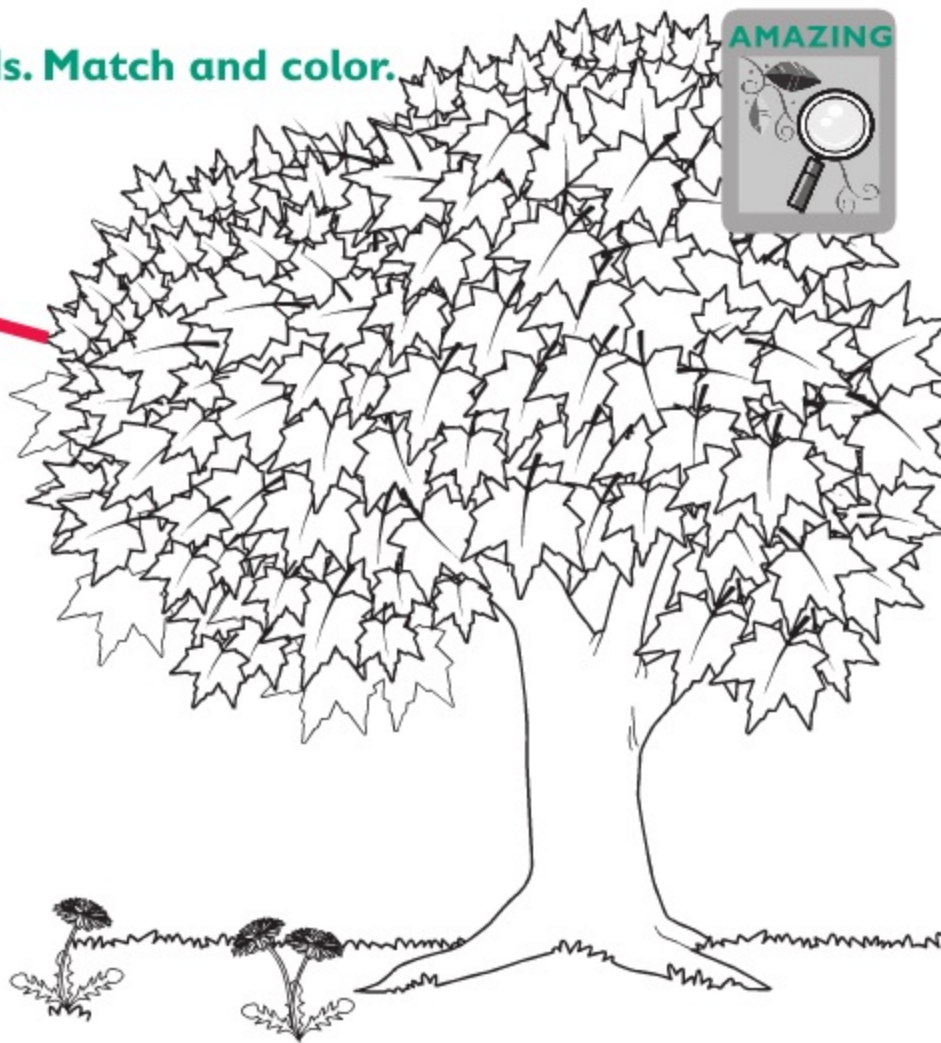

RECYCLE

Draw how you recycle.



5

EATING OUT

What is wrong? Find and circle.

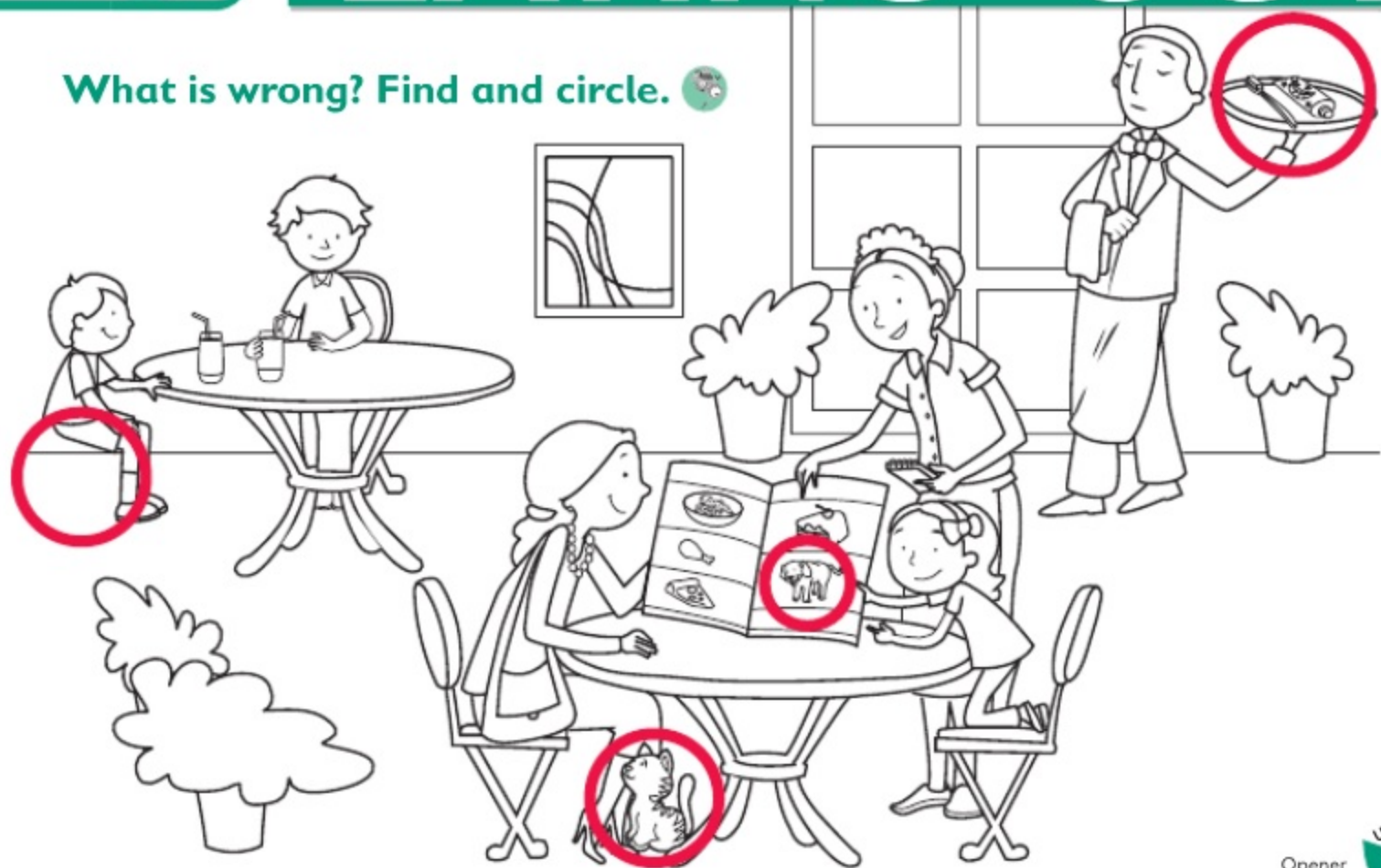

What is each person missing? Look and match.

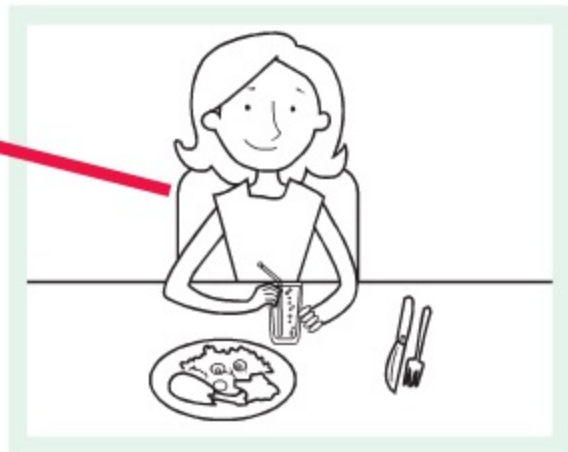
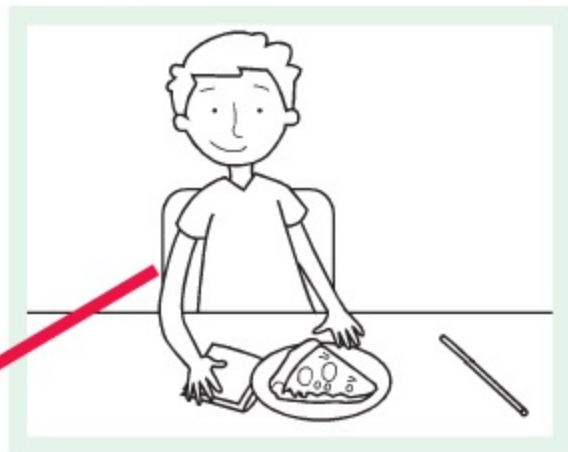

✂ Cut out and paste. Color.



What do you want to eat and drink? Draw and say.

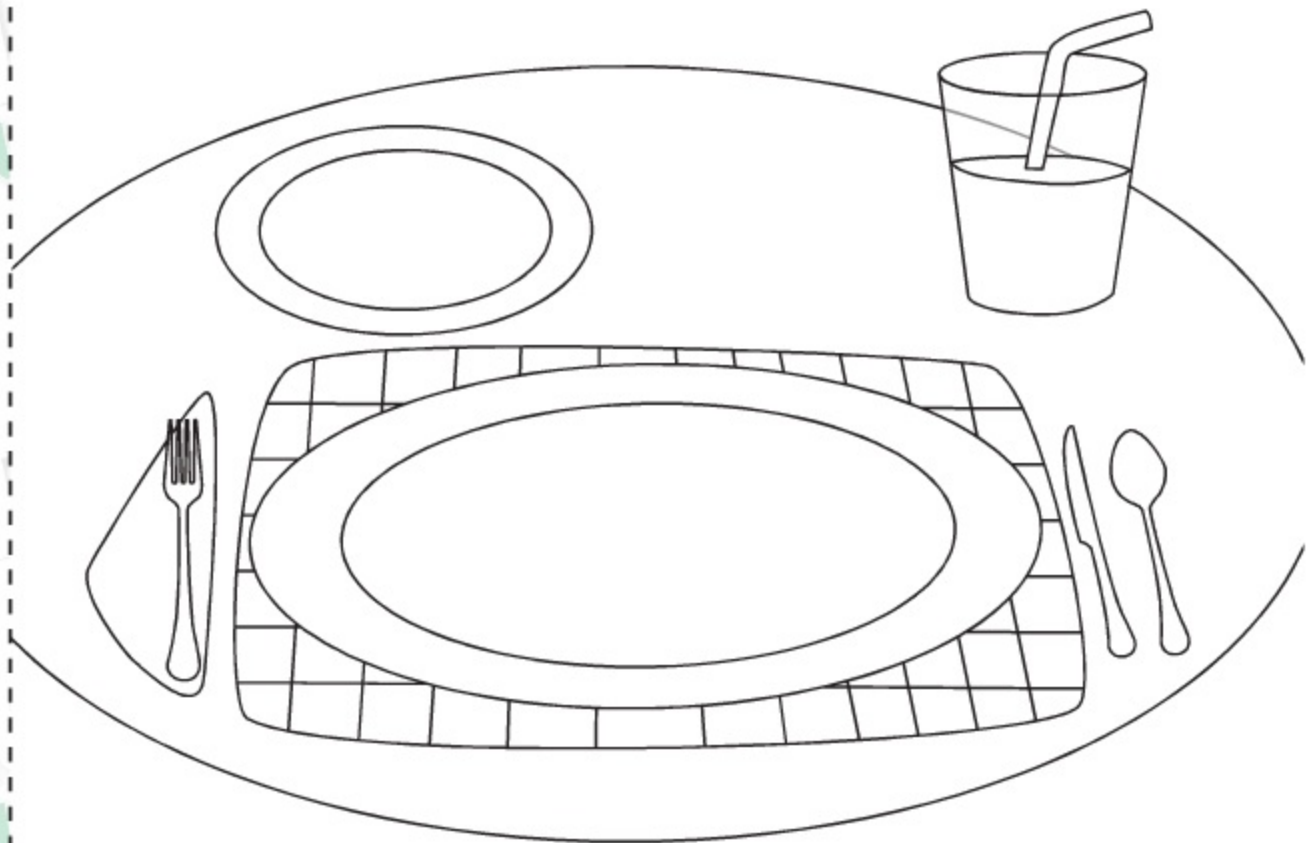

Trace and match. Trace, write, and read.

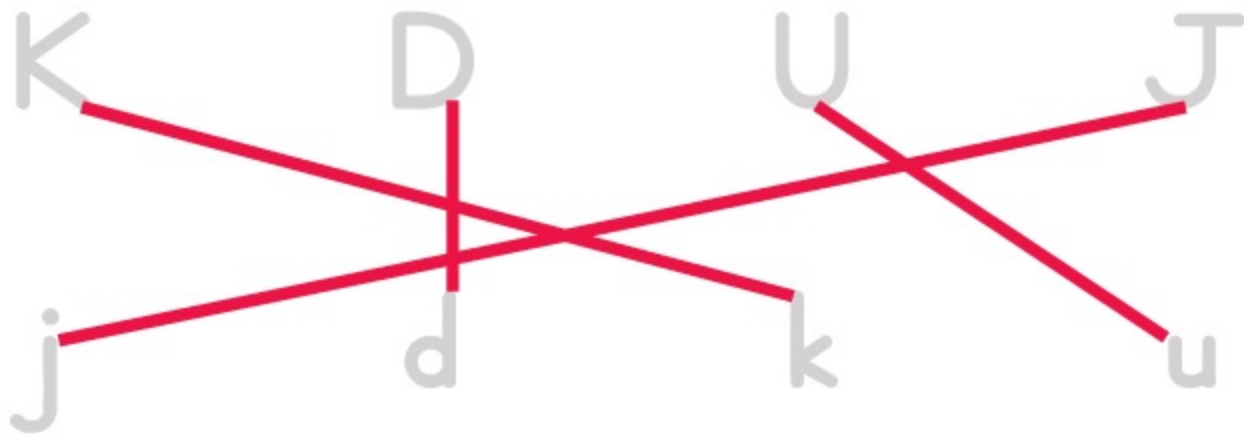

It is a duck.



It is a jacket.



VALUES

Who is helping others? Color the frame. Draw.



What about you?



Look and listen. Color the food that Grandma orders.

Lunch with Grandma

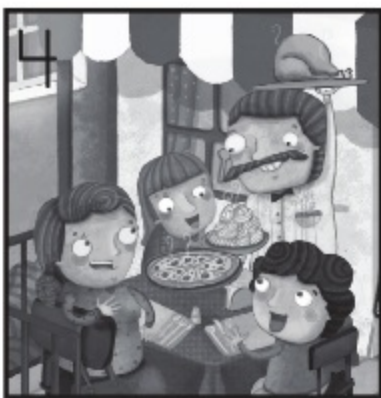

What does Grandma order?

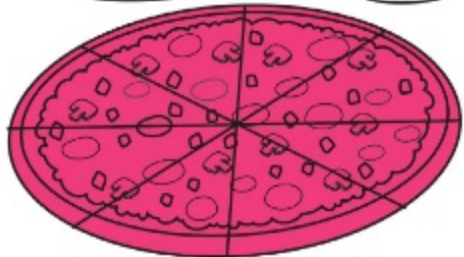

How old are they? Count and circle the correct speech bubbles.

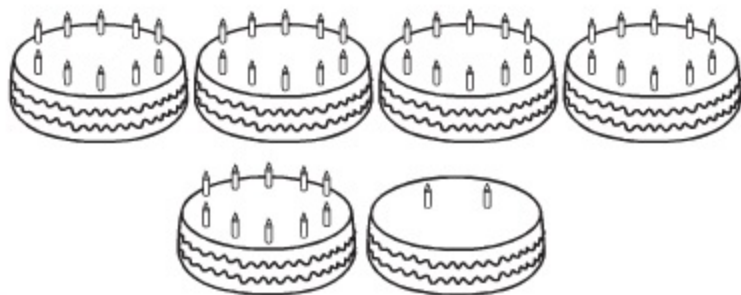

I'm 52!

I'm 54!

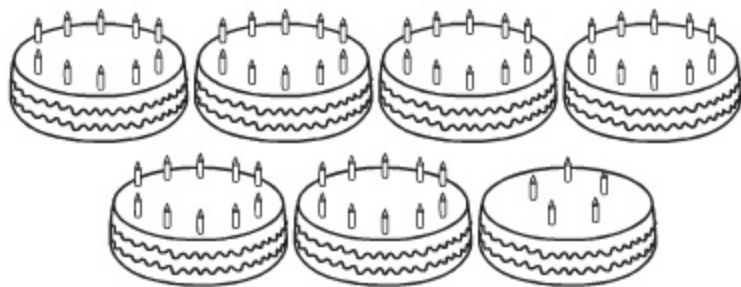

I'm 63!

I'm 65!



Look at the patterns in the fruit and vegetables. Match.

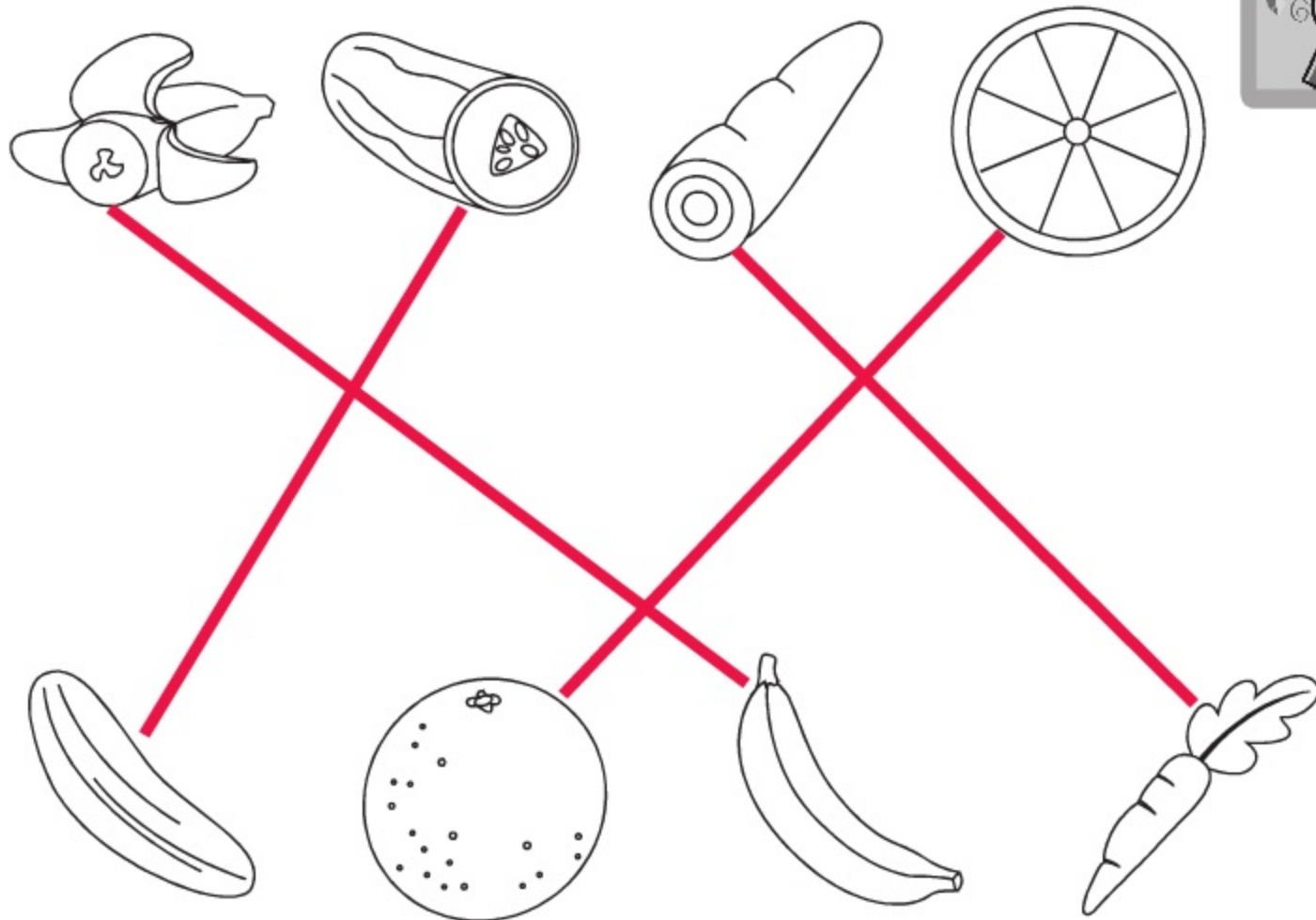
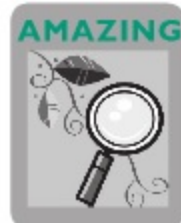



EATING OUT

Draw your favorite restaurant.



6

OUR THINGS

What is wrong? Find and circle.



What is each person missing? Look and match.

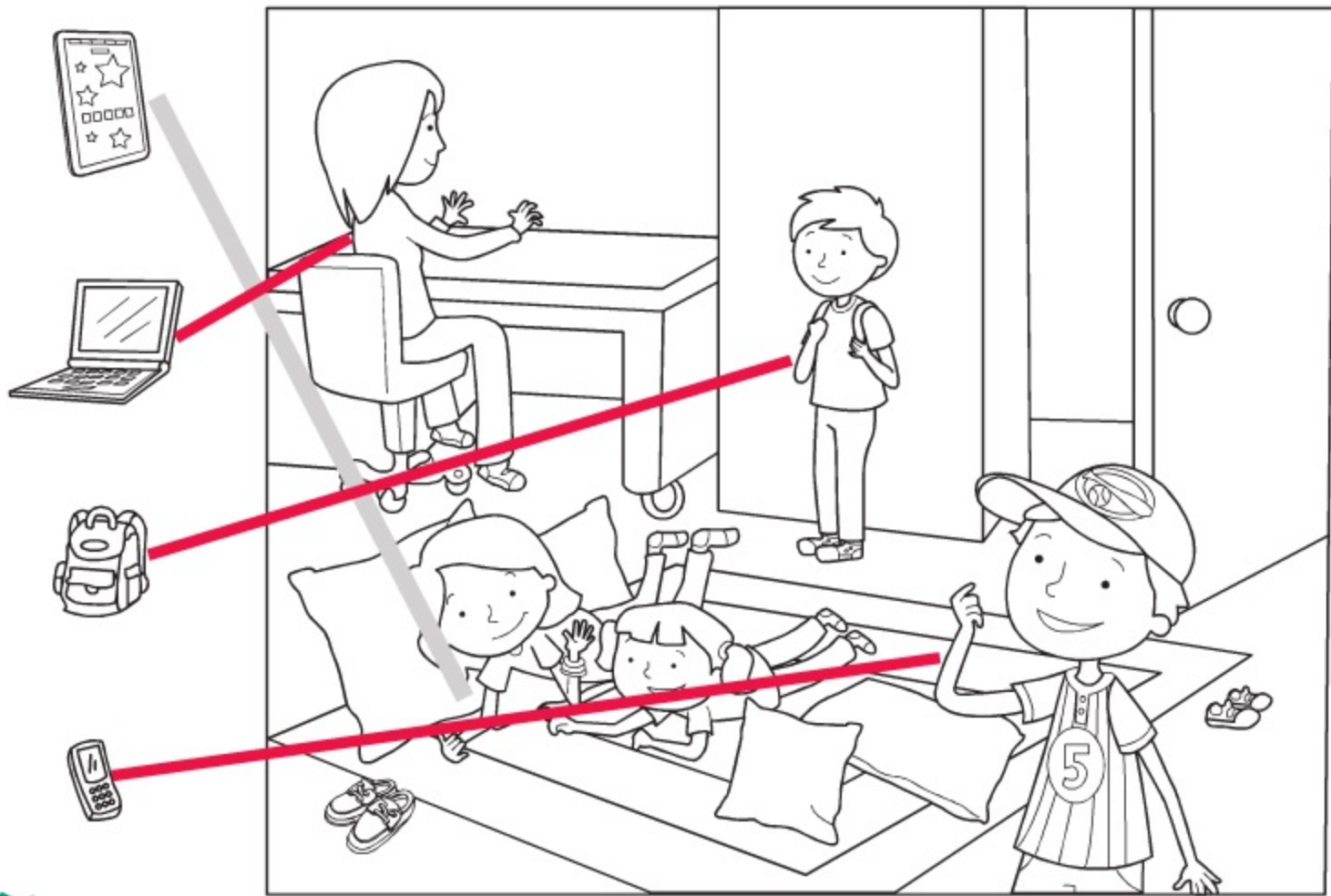

Look and circle the differences.

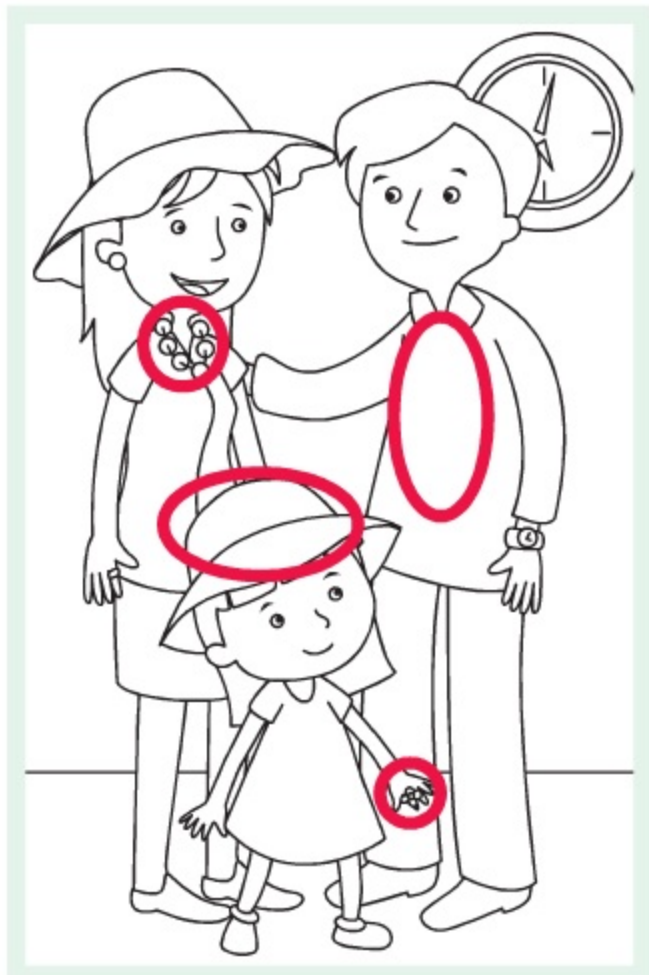
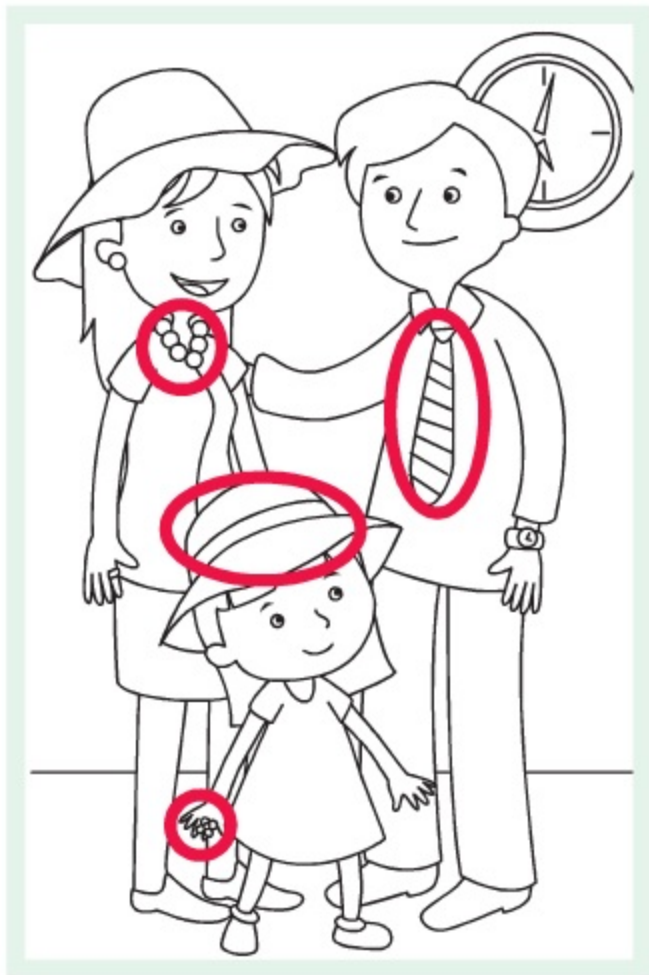

Trace, read, and color the corresponding item.

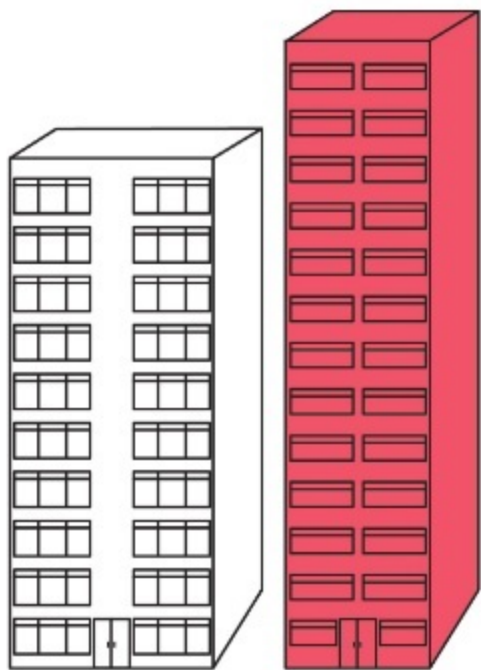

taller

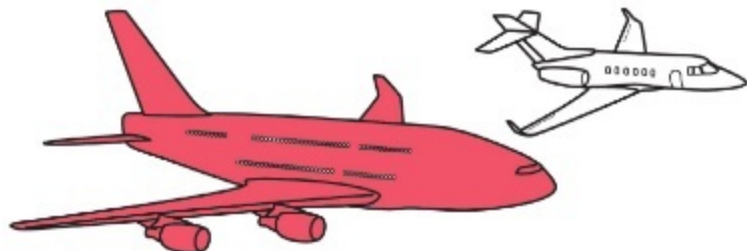

bigger



longer

Trace and match. Then trace, read, and color.

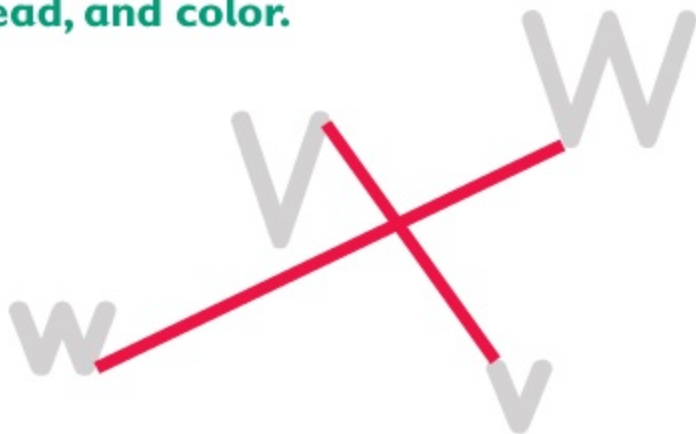
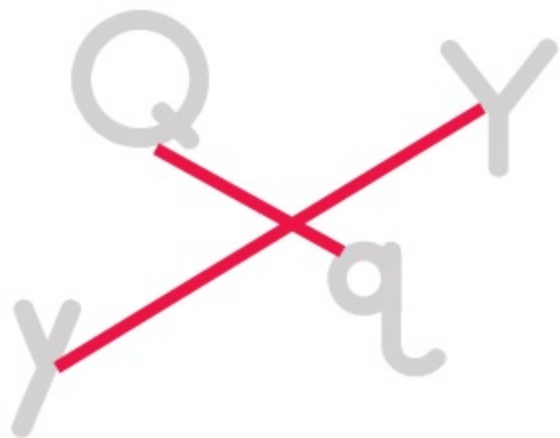

It is a red



It is a yellow

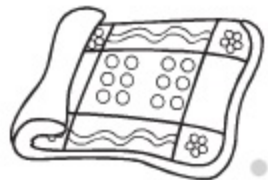

VALUES

Is she being neat? Look and draw a happy or a sad face. Then draw yourself and complete the face.



What about you?

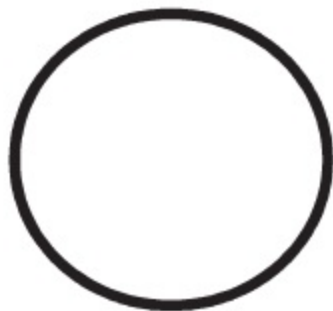



Cut out, listen, and paste.

At the Store



1



2

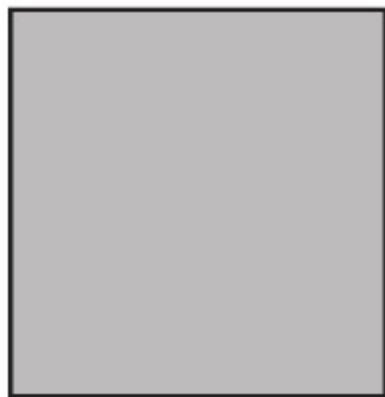

3

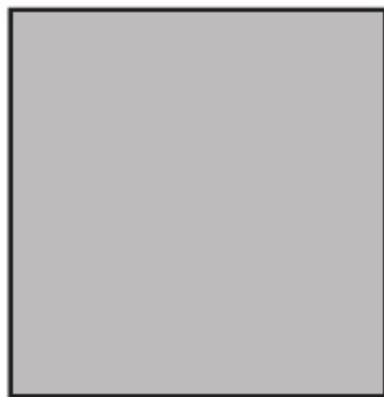

4



Complete the number line. Count and answer.

70 71 72 73 74 75 76 77 78 79

80 81 82 83 84 85 86 87 88 89

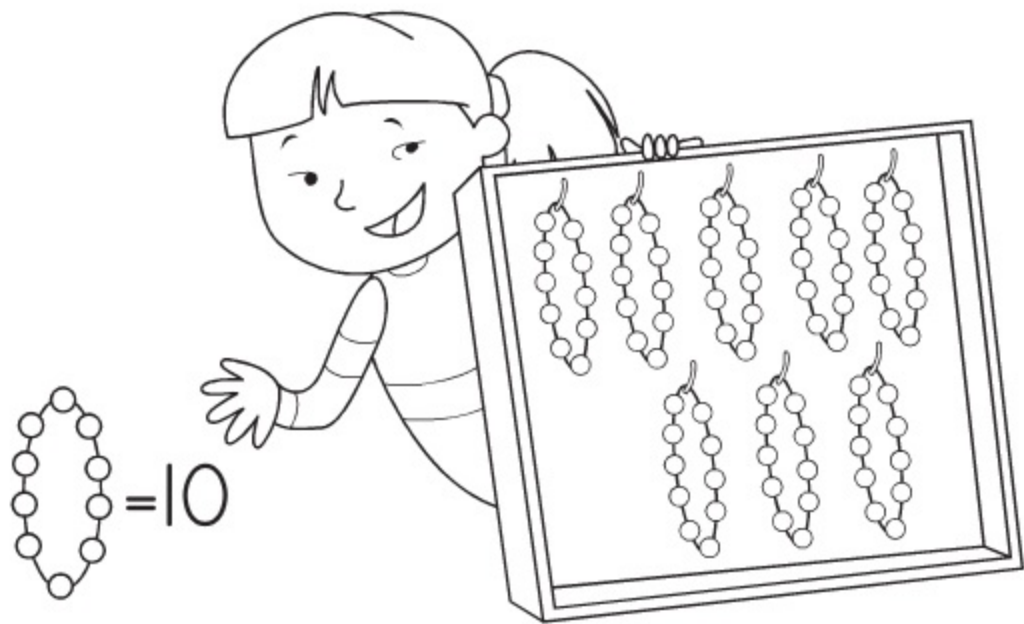

How many beads? 80



Look and color by number.

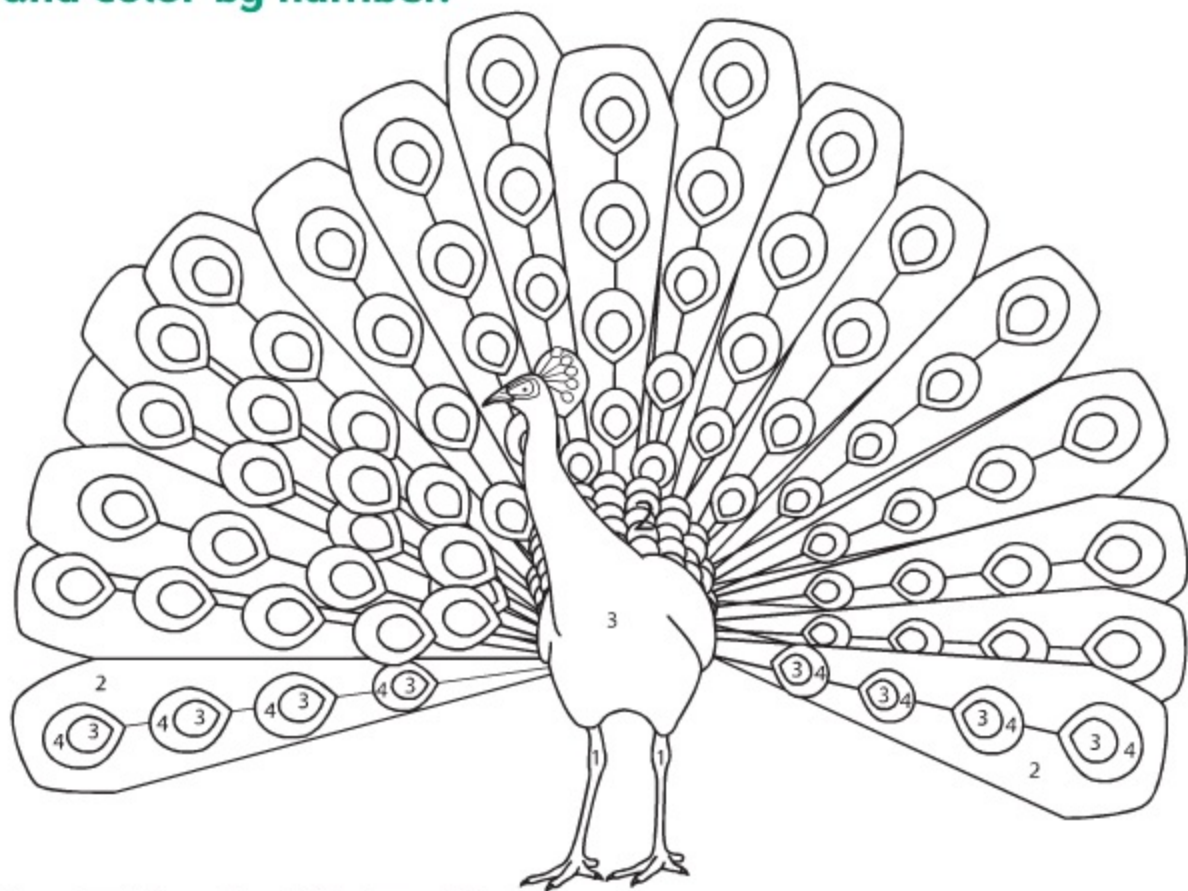

1  brown 2  green

3  blue 4  orange

OUR THINGS

Draw your favorite things.



7

ANIMALS

What is wrong? Find and circle.

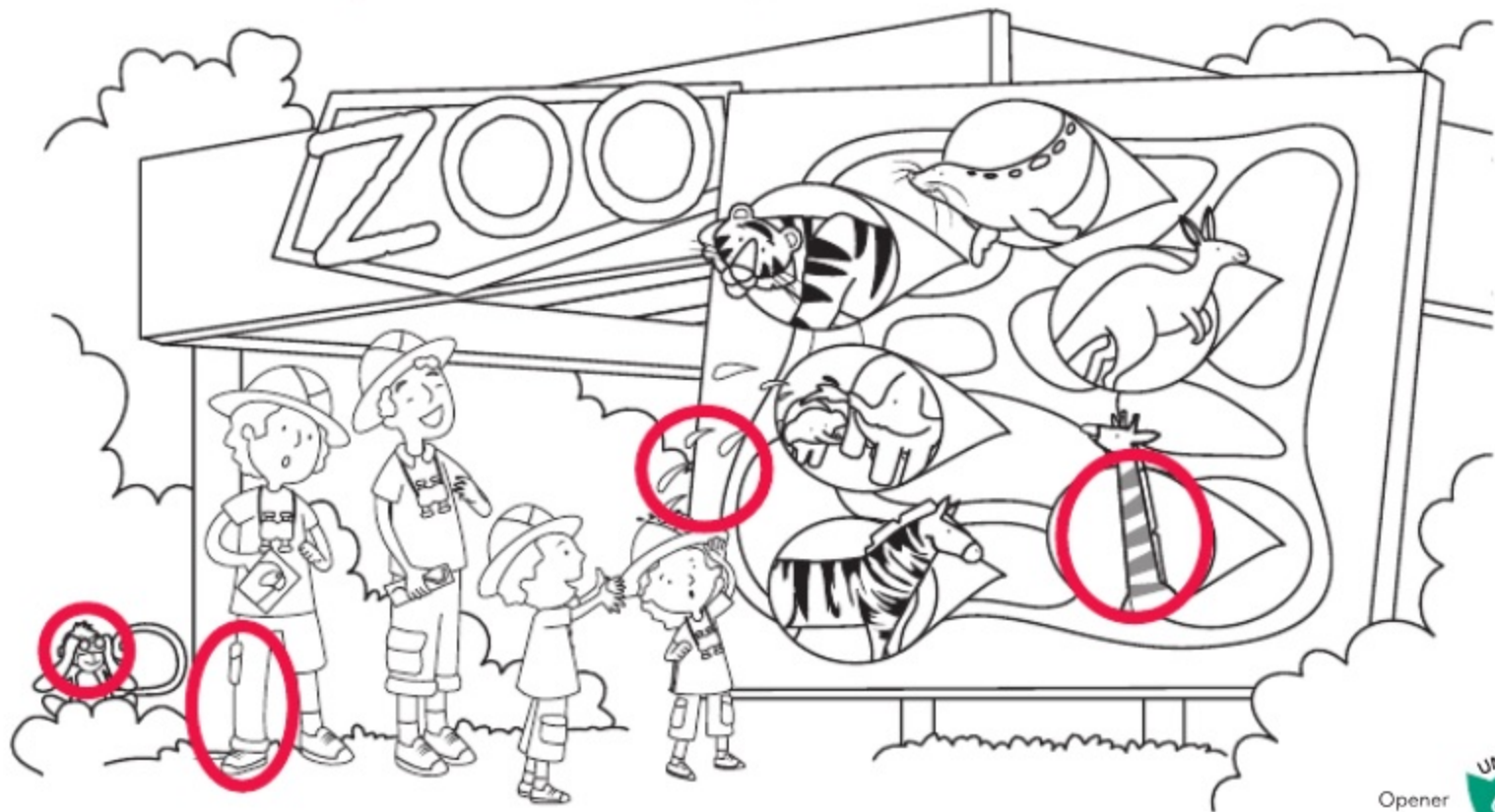

Look and match.



✂ **Cut out and paste.**

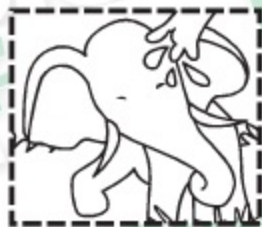
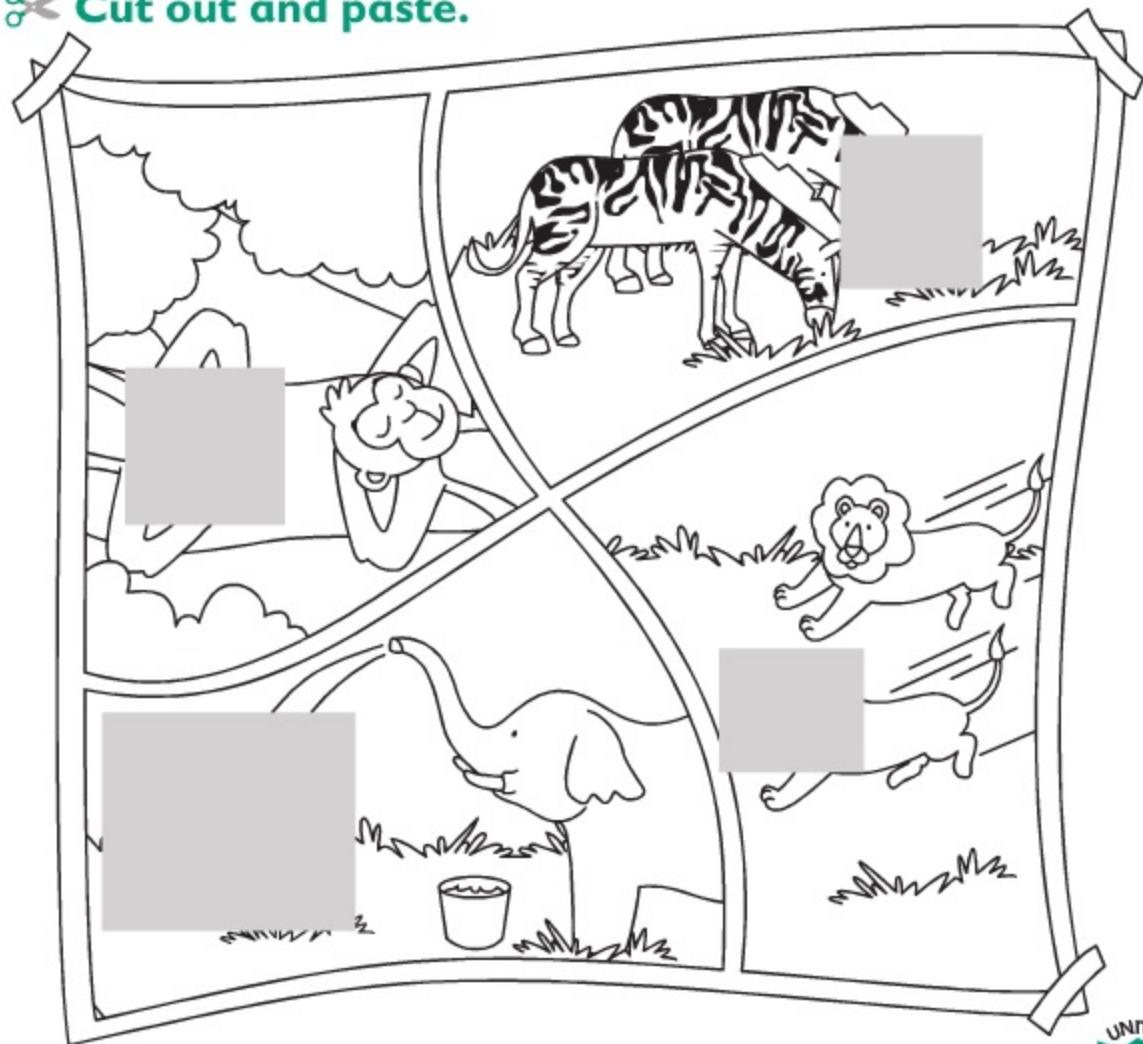

Look and draw the morning, afternoon, and night sky.
Then say what the zookeeper does.



morning



afternoon



night

Trace and write. Trace, read, and circle.



I see a zebra.



I see an ox.



I see a zoo.





How do you and your friends work as a team?



Look and listen. Draw what they see at the zoo.

At the Zoo

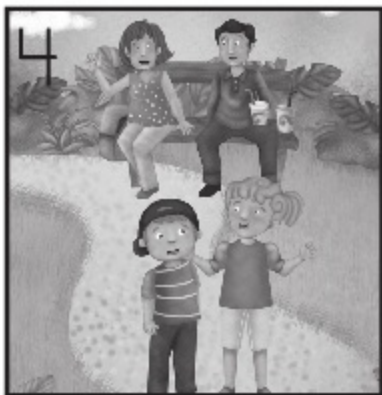
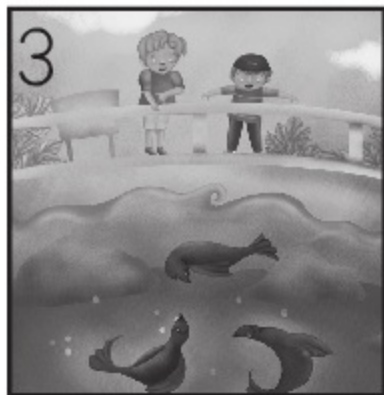
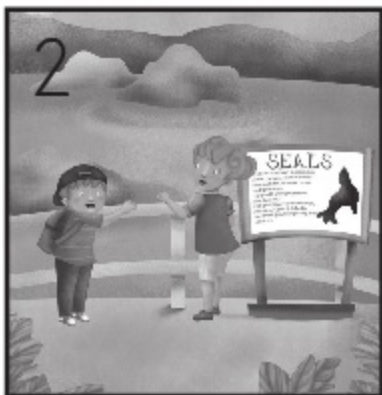

What do they see at the zoo?



Connect the dots in number order. Name the animals.

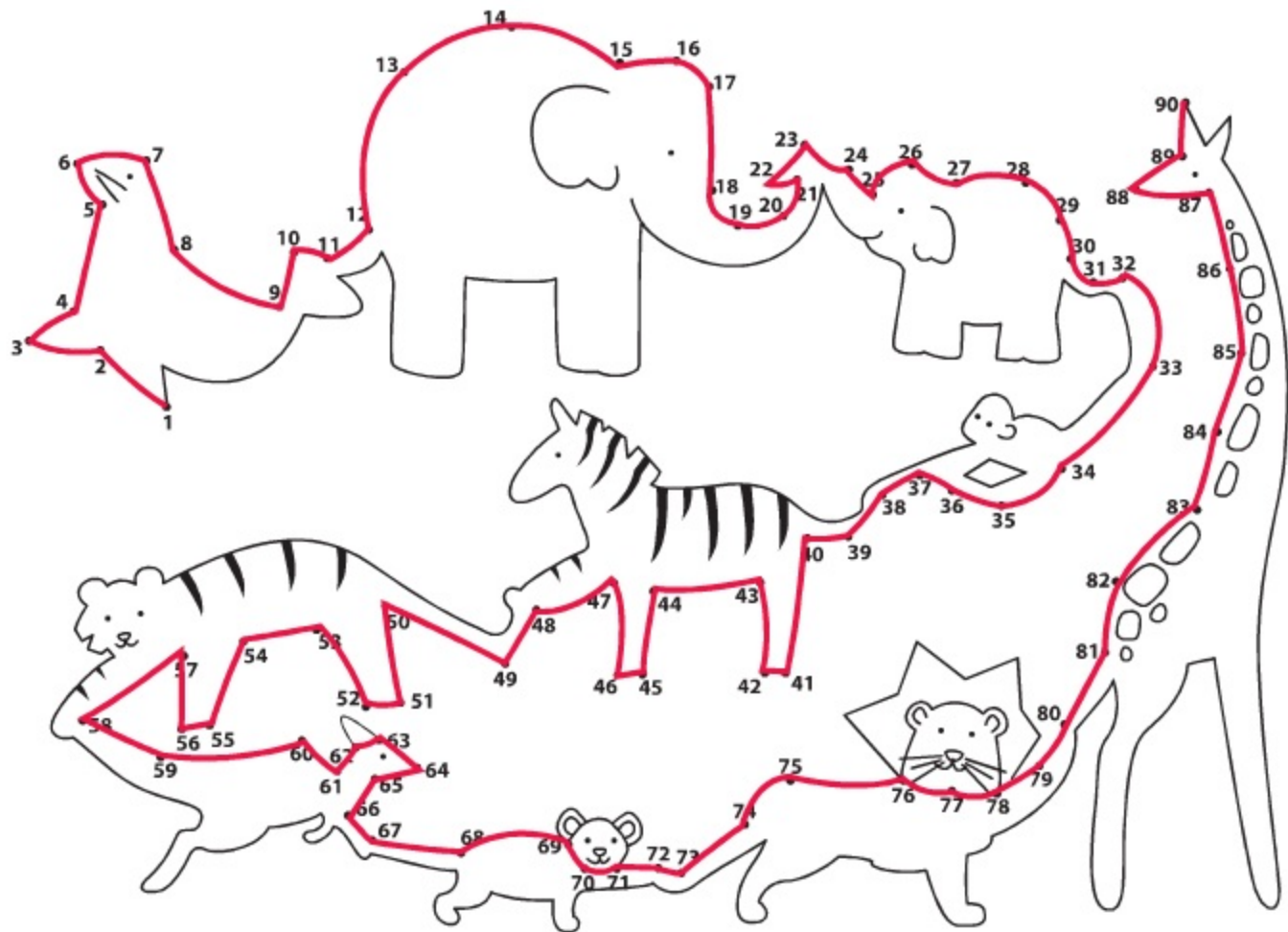

Circle the animals and plants that live underwater.
Then draw more animals and plants and color.

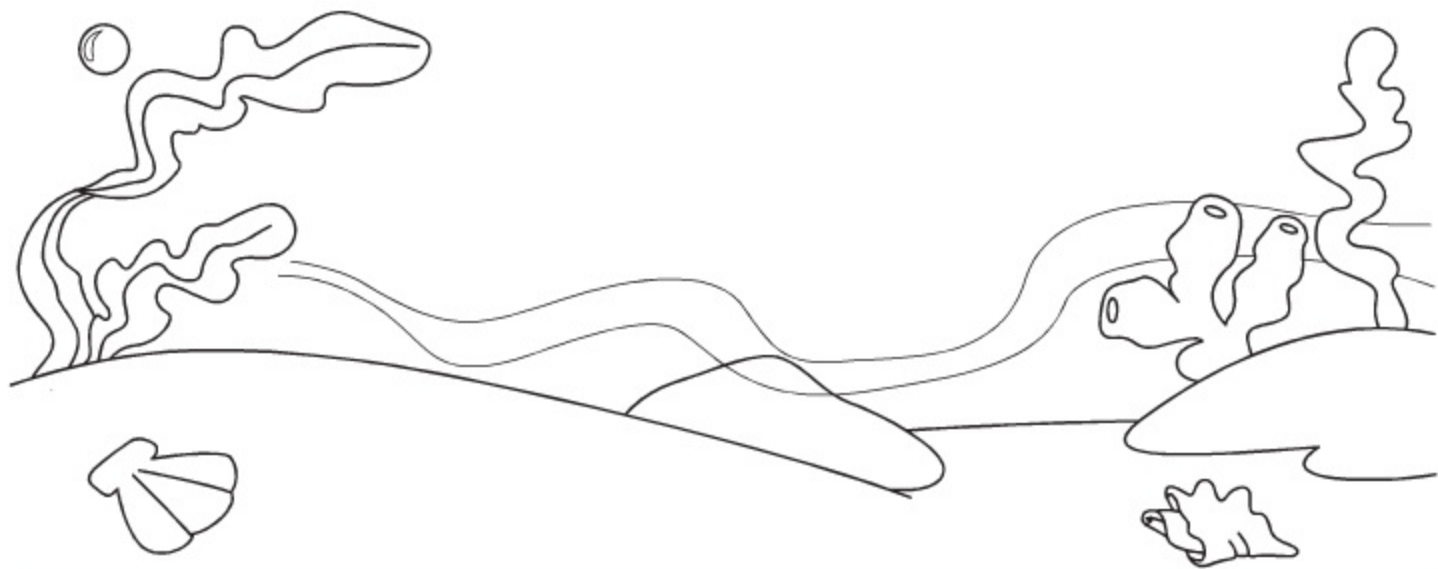
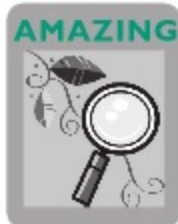

Amazing: Science Connection: *jellyfish, fish, coral, octopus*

ANIMALS

Draw your favorite wild animals.



8

PLACES

What is wrong? Find and circle.

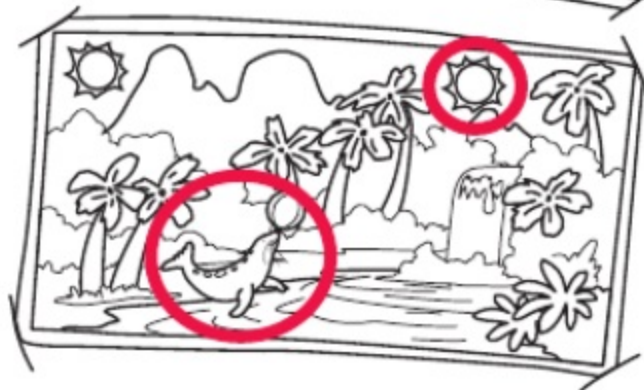

Where do you want to go? Circle. Then draw yourself in that place.

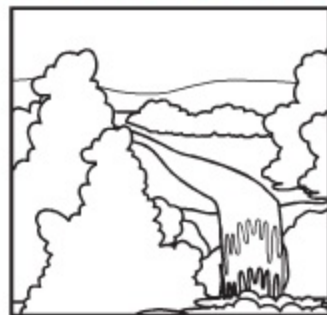
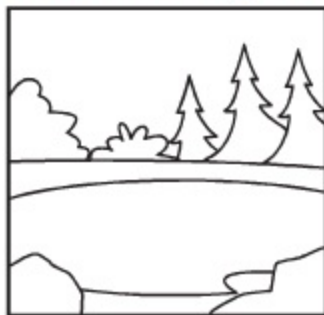
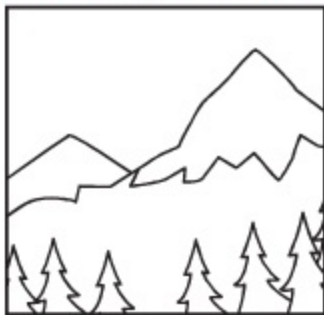

✂ Cut out and paste.

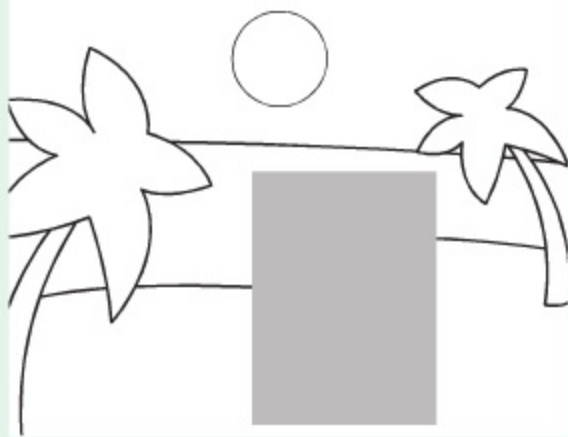
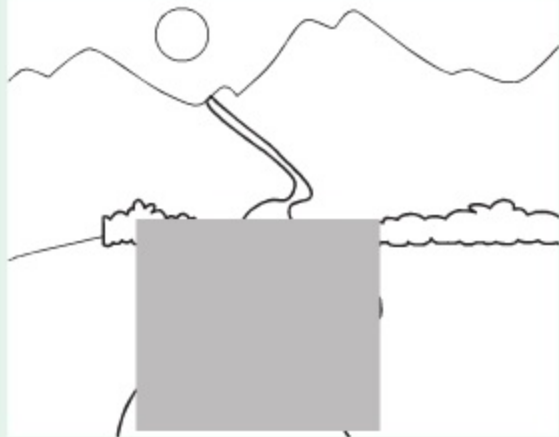
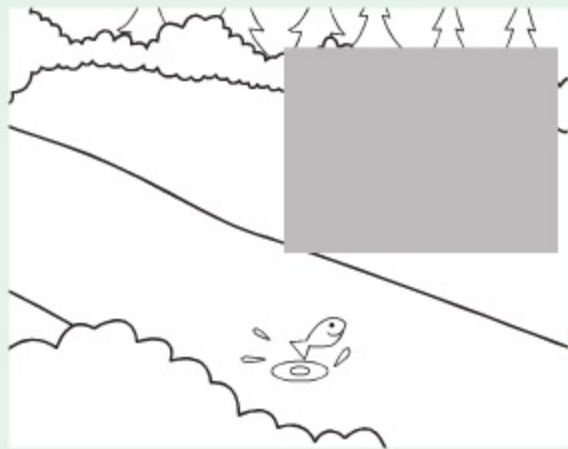
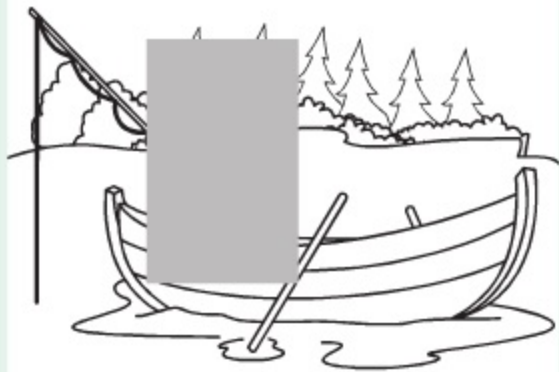

Trace, read, and match.

1 ————— first



2 ————— then



3 ————— last



Trace and read. Look and number.

1. I see a big
bird in a boat.

2



2. I see a big
bear in a tent.

1



VALUES

Is he sharing? Look and draw a happy or a sad face.
Then draw yourself and complete the face.

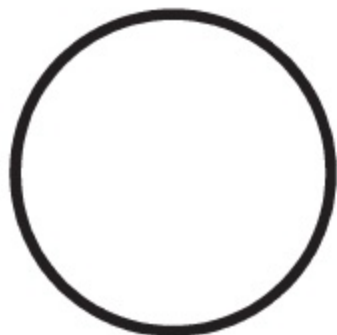
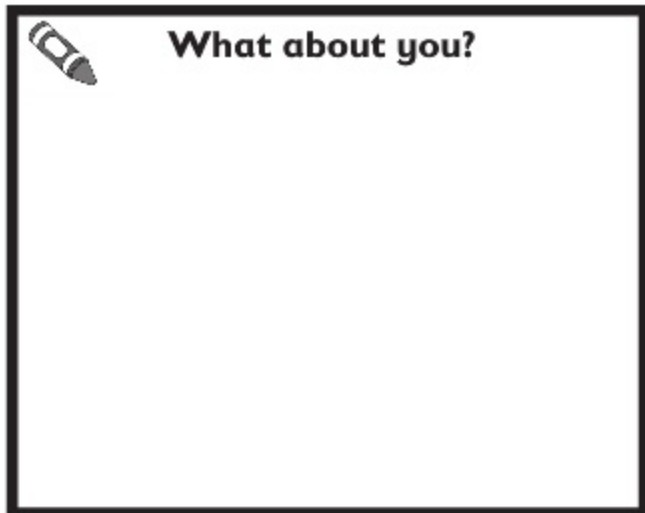



Look and listen. Color the animals that they see.

Camping

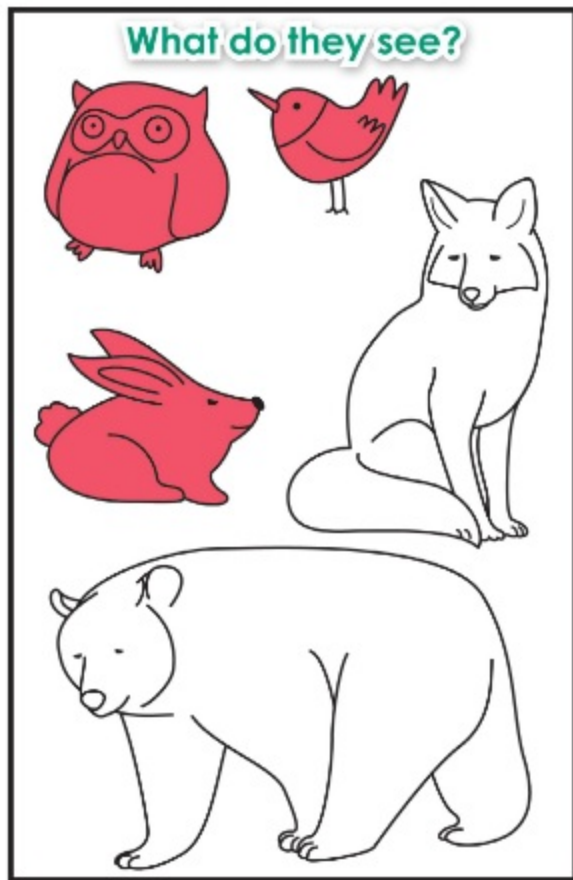
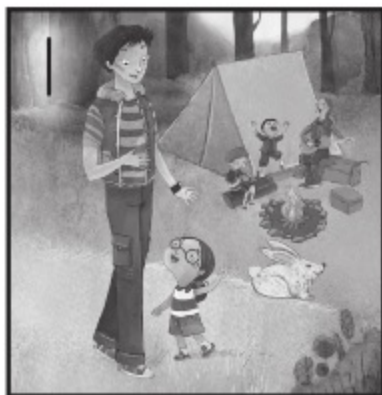

Trace and write the time. Then draw what you do at each time of the day.

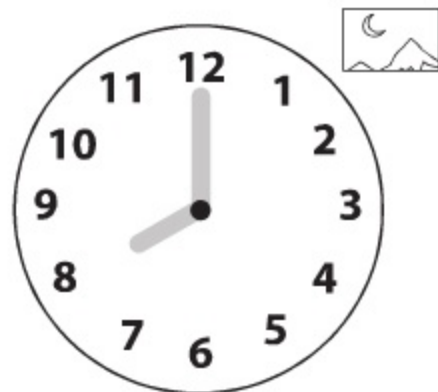
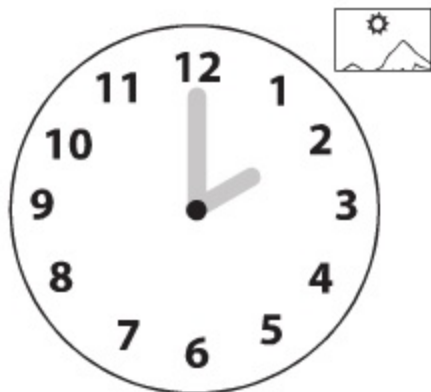
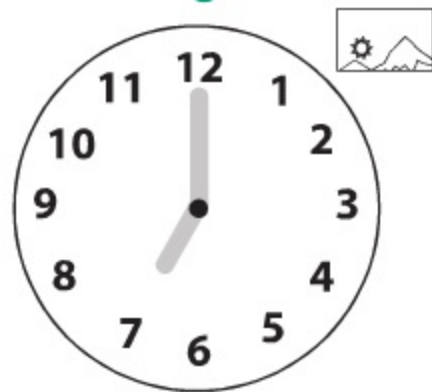

7 o'clock

2

o'clock

8

o'clock



Trace, read, and color. Draw.



first

then

last

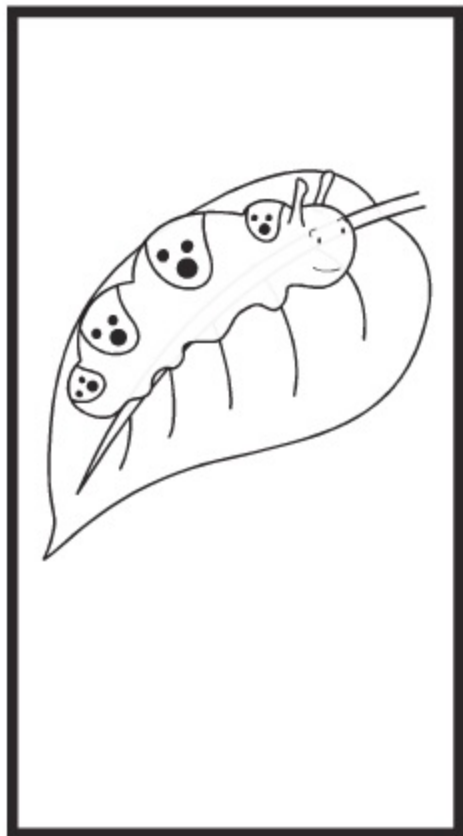

PLACES

Draw yourself on vacation doing your favorite activity.



9

SHOW TIME!

Look and review.

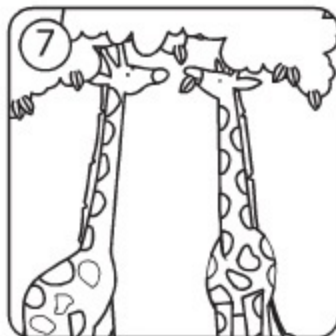
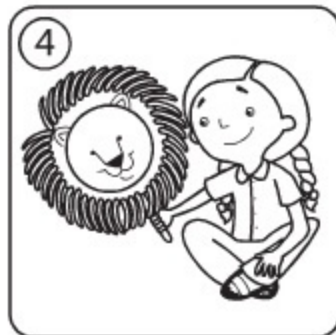
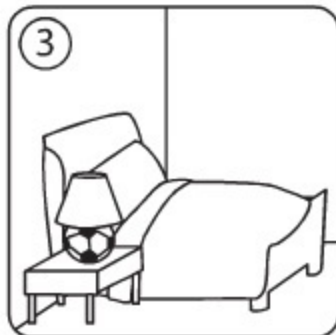

Review Units 1–8: music teacher, sleepy, bedroom/bed, paper plate/stick/string, cake, hat/necklace, giraffes/eating, lake/fishing

Unit 1: Look and say. Who are they? What do they do?

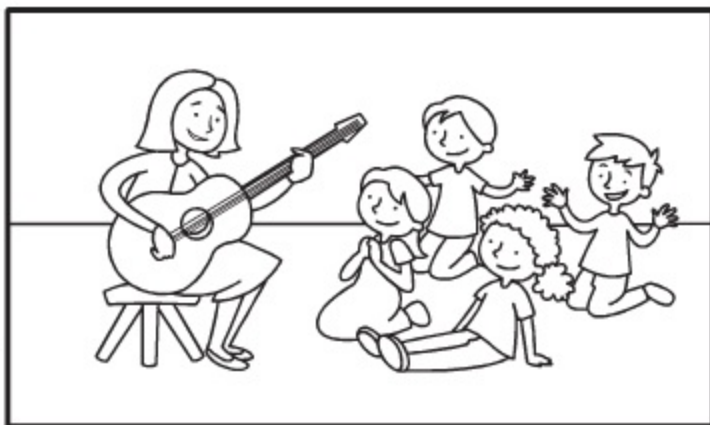

Unit 2: Are you OK? Spin a crayon and say.

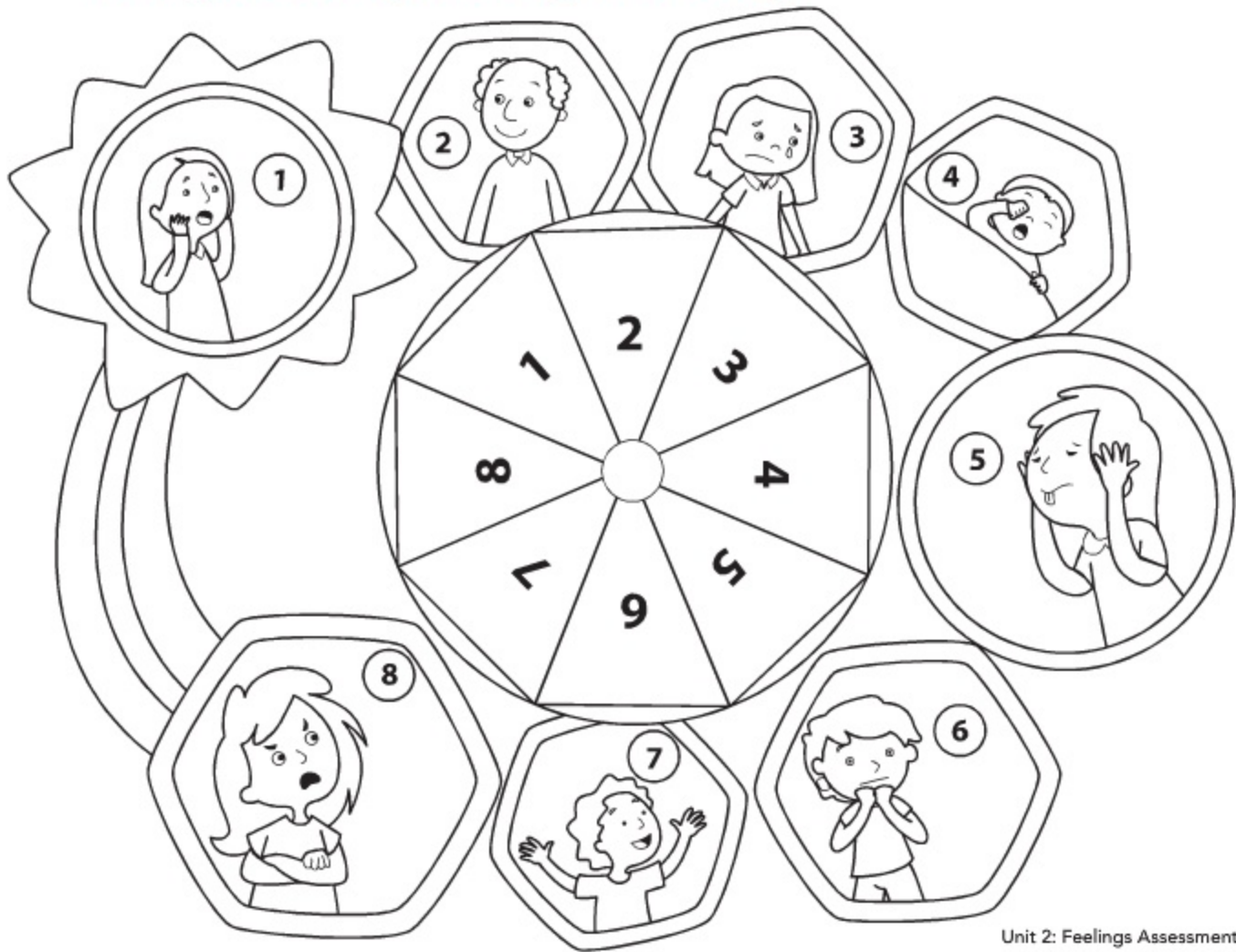



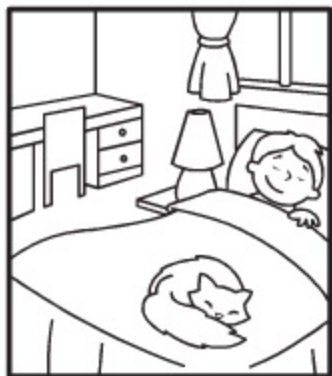



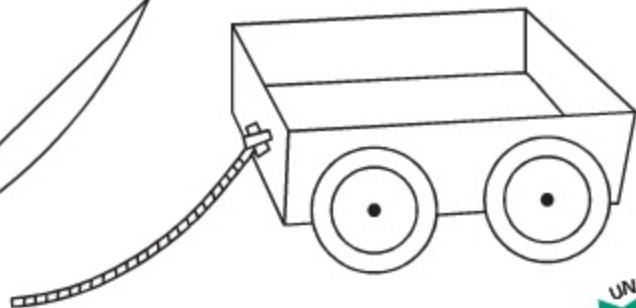
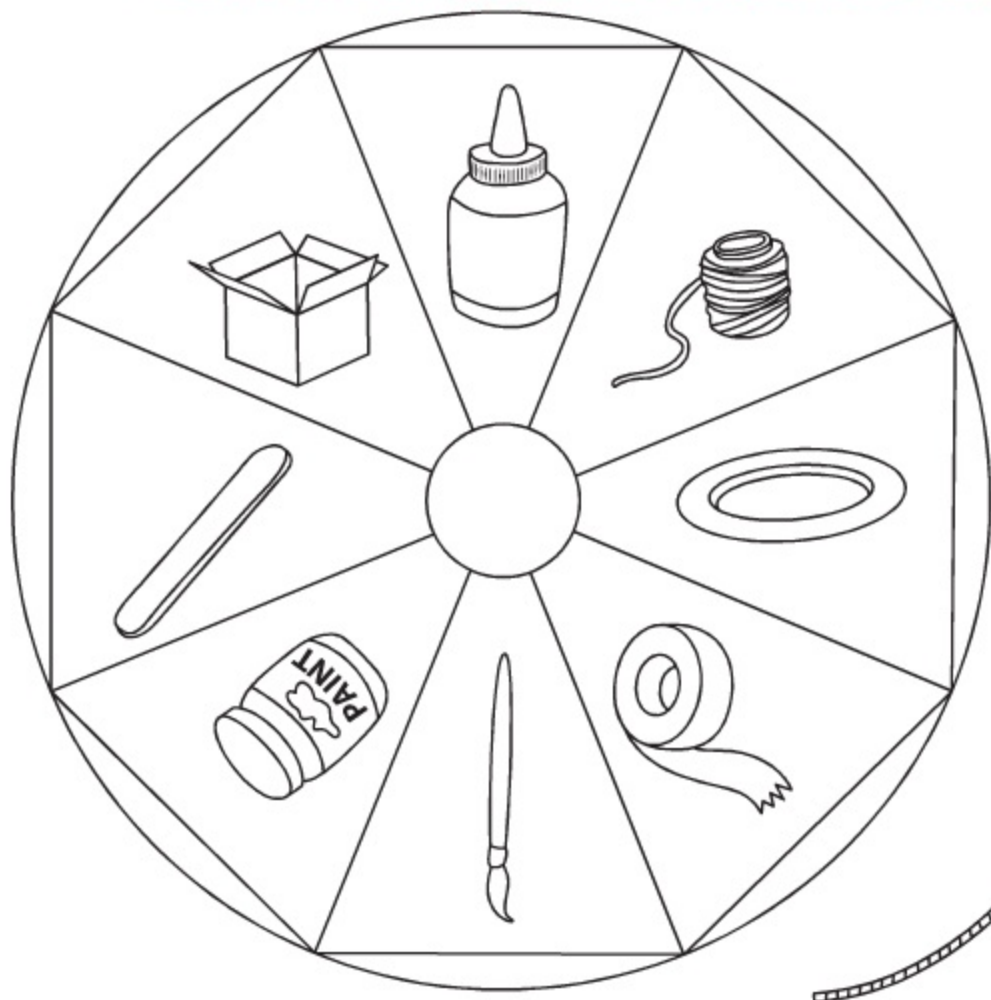



Unit 3: Name the places in the house. What are the boy and his cat doing?



Unit 4: Do you need... ? Spin a crayon and say.



Unit 5: Play the Restaurant Game. Ask politely for the items on the game board.

START						
 <p>May I have _____, please.</p> <p>Yes, of course.</p>						
						
						
FINISH						

Unit 6: Where is the... ? Circle and say.

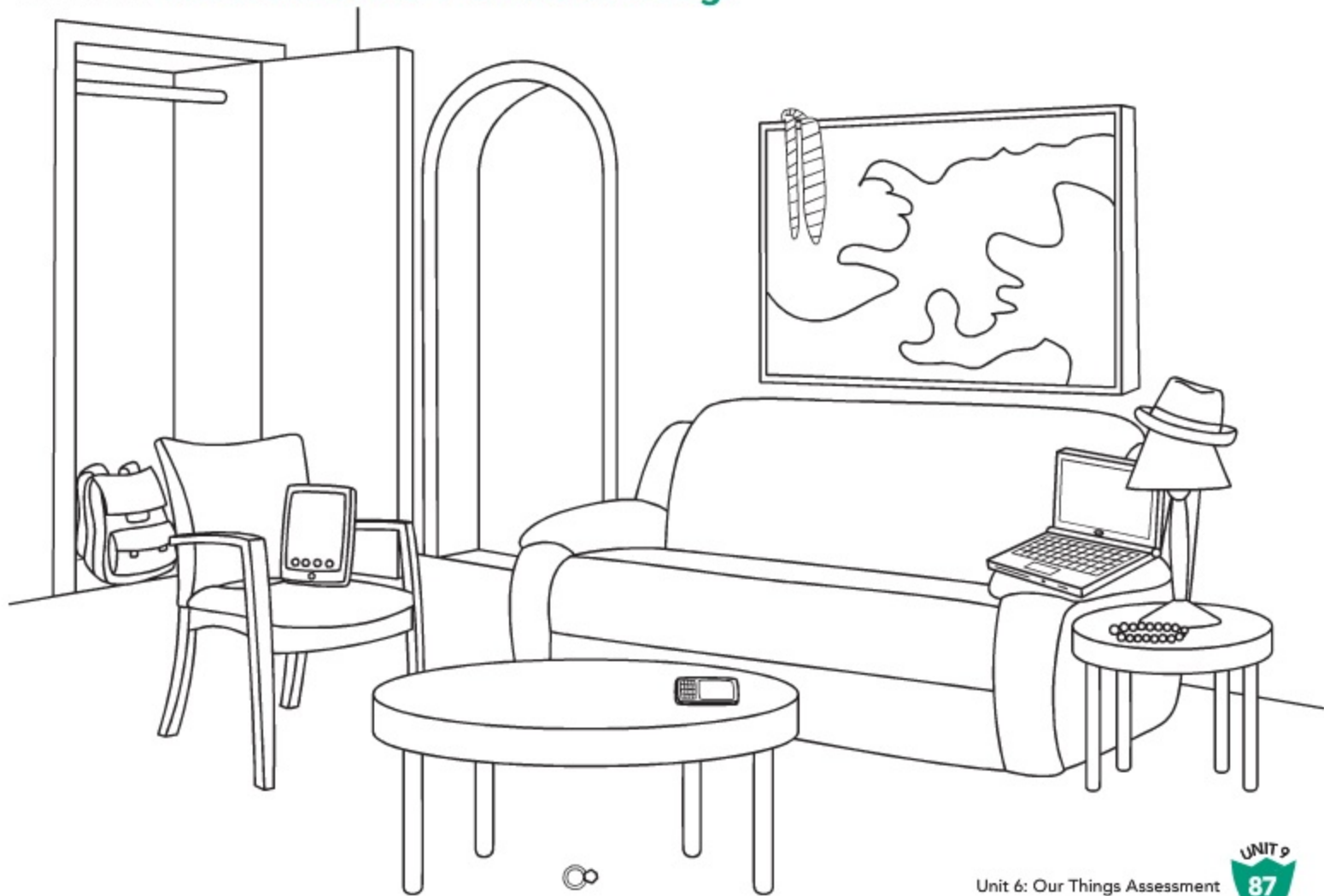

**Unit 7: Draw your path through the zoo. What do you see?
What are the animals doing? Look and say.**

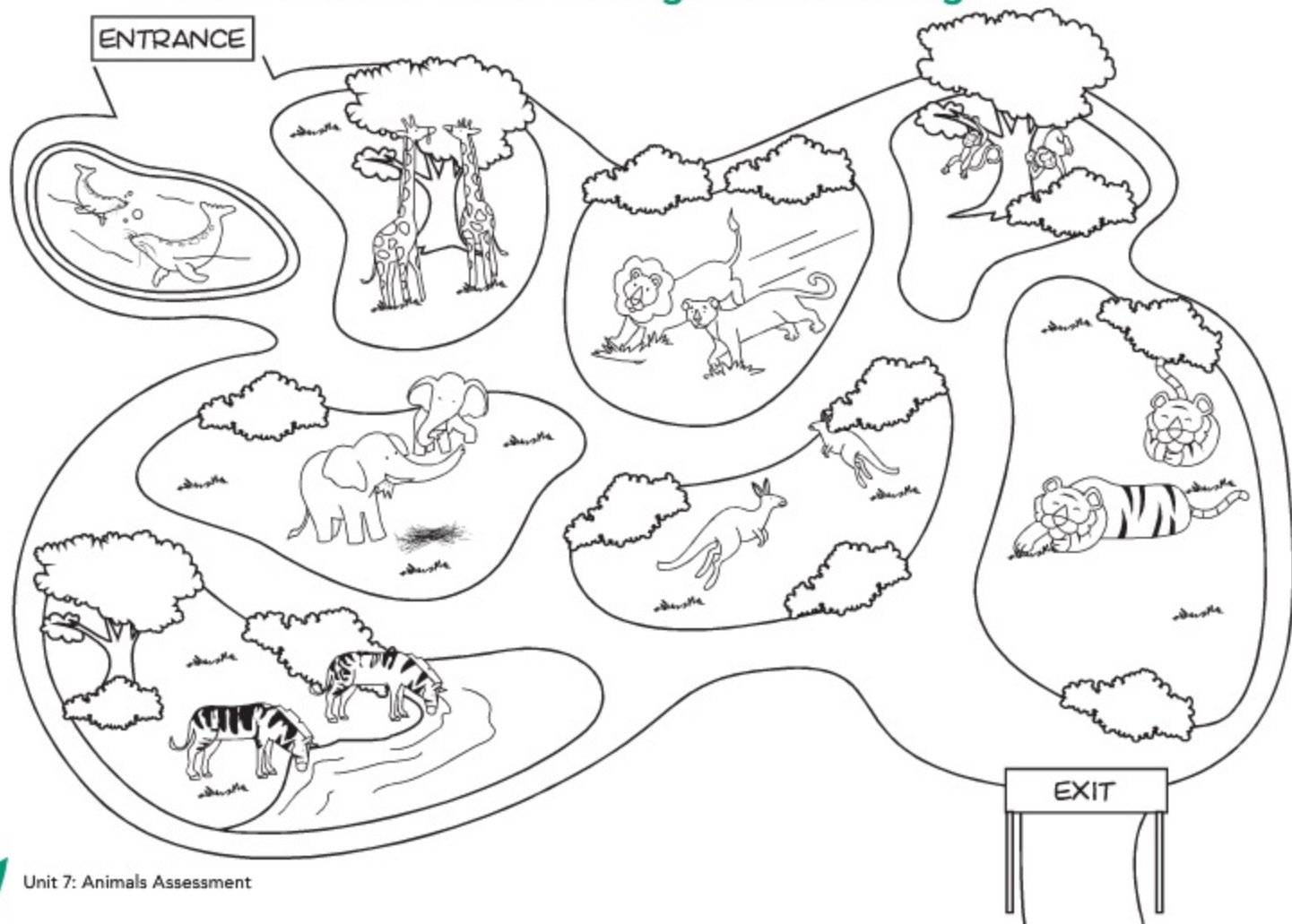

Unit 8: Where do you want to go? What can you do there?
Point and say.

